



We know how water works

SCAVENGER™ Effluent & Sewage Ejector Pumps

Rugged submersible pumps for residential, commercial, municipal, and industrial applications.

- Unique triple seal design
- ABS patented Contra Block® impeller with adjustable wear plate system, for clog-free operation.
- Single phase models through 5 HP. Three phase models through 10 HP
- Discharges, 1 1/4 to 4"
- High torque capacitor start single phase motors
- Rugged cast iron construction with stainless steel fasteners and motor shaft
- Oil filled motors (non-toxic oil)
- Stainless steel open loop lifting bale for ease of removal
- Optional seal leakage sensor probe available on all EJ models
- UL 778 and CSA C22.2-108 approval on all models



SCAVENGER™ Effluent & Sewage Ejector Pumps

Effluent Pumps

1 fi Inch Discharge

Model	HP	Phase*	RPM	Voltage**	Amps	Discharge	Solids Size	Max Head (feet)	Max Flow (gpm)	Weight (Lbs.)
EF 05W-1H	>	1	3450	115, 208-230	15.0, 8.3-7.5	Horiz. NPT	5/8"	73	44	68
EF 10W-1H	1	1	3450	208-230	14.4-13.0	Horiz. NPT	5/8"	108	44	70

2 Inch Discharge

EF 10W-2	1	1	3450	208-230	14.4-13.0	Vert. NPT	3/4"	73	160	62
EF 10D-2	1	3	3450	208-230/460, 575	6.4-5.8/2.9, 2.3	Vert. NPT	3/4"	73	160	57

Sewage Ejector Pumps

2 Inch Discharge

Model	HP	Phase*	RPM	Voltage**	Amps	Discharge	Solids Size	Max Head (feet)	Max Flow (gpm)	Weight (Lbs.)
EJ 07W-2	3/4	1	1750	115, 208-230	14.0 / 7.7-7.0	Horiz. Flange ‡	2"	25	200	84
EJ 07D-2	3/4	3	1750	208-230/460, 575	5.5-5.0/2.5, 2.0	Horiz. Flange ‡	2"	25	200	80
EJ 10W-2	1	1	1750	208-230	11.1-10.0	Horiz. Flange ‡	2"	30	240	84
EJ 10D-2	1	3	1750	208-230/460, 575	5.5-5.0/2.5, 2.0	Horiz. Flange ‡	2"	30	240	80
EJ 15W-2	1>	1	1750	208-230	16.6-15.0	Horiz. Flange ‡	2"	37	300	90
EJ 15D-2	1>	3	1750	208-230/460, 575	7.7-7.0/3.5, 2.8	Horiz. Flange ‡	2"	37	300	84
EJ 20W-2	2	1	1750	208-230	21.0-19.0	Horiz. Flange ‡	2"	45	320	90
EJ 20D-2	2	3	1750	208-230/460, 575	9.9-9.0/4.5, 3.6	Horiz. Flange ‡	2"	45	320	84

3 Inch Discharge

EJ 10W-3	1	1	1750	208-230	11.1-10.0	Horiz. Flange	2>"	30	265	77
EJ 10D-3	1	3	1750	208-230/460, 575	5.5-5.0/2.5, 2.0	Horiz. Flange	2>"	30	265	70
EJ 15W-3	1>	1	1750	208-230	16.6-15.0	Horiz. Flange	2>"	35	300	90
EJ 15D-3	1>	3	1750	208-230/460, 575	7.7-7.0/3.5, 2.8	Horiz. Flange	2>"	35	300	84
EJ 20W-3	2	1	1750	208-230	21.0-19.0	Horiz. Flange	2>"	44	330	90
EJ 20D-3	2	3	1750	208-230/460, 575	9.9-9.0/4.5, 3.6	Horiz. Flange	2>"	44	330	84
EJ 30W-3	3	1	1750	208-230	25.4-23.0	Horiz. Flange	2>"	50	450	147
EJ 30D-3	3	3	1750	208-230/460, 575	14.4-13.0/6.5, 5.2	Horiz. Flange	2>"	50	450	143
EJ 50W-3	5	1	1750	208-230	29.9-27.0	Horiz. Flange	2>"	57	470	161
EJ 50D-3	5	3	1750	208-230/460, 575	21.0-19.0/9.5, 7.6	Horiz. Flange	2>"	57	470	154
EJ 75D-3	7>	3	1750	208-230/460, 575	25.4-23.0/11.5, 9.2	Horiz. Flange	2>"	67	525	161

4 Inch Discharge

EJ 30W-4	3	1	1750	208-230	25.4-23.0	Horiz. Flange	3"	46	525	154
EJ 30D-4	3	3	1750	208-230/460, 575	14.4-13.0/6.5, 5.2	Horiz. Flange	3"	46	525	150
EJ 50W-4	5	1	1750	208-230	29.9-27.0	Horiz. Flange	3"	52	550	165
EJ 50D-4	5	3	1750	208-230/460, 575	21.0-19.0/9.5, 7.6	Horiz. Flange	3"	52	550	158
EJ 75D-4	7>	3	1750	208-230/460, 575	25.4-23.0/11.5, 9.2	Horiz. Flange	3"	61	600	165
EJ 100D-4	10	3	1750	208-230/460, 575	31.0-28.0/14.0, 11.2	Horiz. Flange	3"	70	620	170

*Single phase pumps from > HP through 2 HP have capacitor and thermal protection built into pump. Single phase pumps from 3 HP through 5 HP require an external capacitor start box or control panel, with overload protection. All three phase pumps require a control panel with overload protection.

** 230 Volt pumps can be operated on 208 volts without modifications.

‡ Pump comes complete with bolt-on discharge elbow, 2" flange x 2" NPT, standard, 2" flange x 3" NPT, optional.

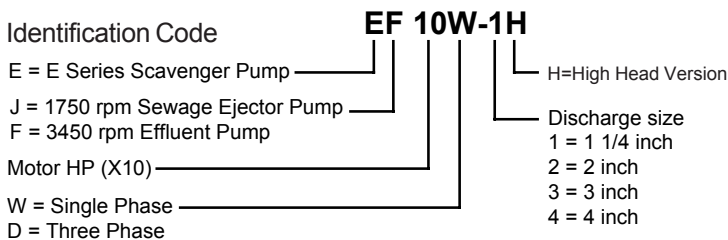

Materials of Construction

Housings & Volute	Cast Iron
Impeller and Wear Plate	Cast Iron
External Hardware	304 Stainless Steel
Motor Shaft	420 Stainless Steel
Mechanical Seals	Carbon/Ceramic (optional Silicon Carbide)
Bearings	Ball Bearings
Motor Windings	Copper (class B or F depending on model)
Start Switch (1 phase)	Solid State Electronic Switch
Power Cable	Thermoplastic Elastomer, 20 feet standard
O-Rings	Buna-N
Oil	Non-Toxic

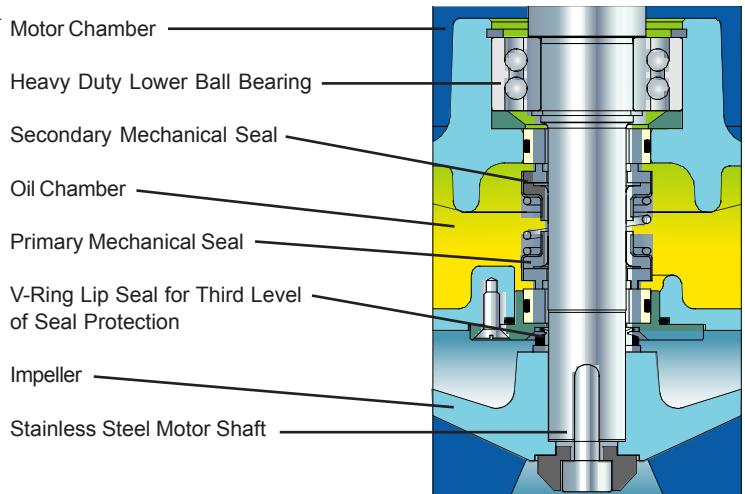

The Scavenger Triple Seal System

This *ABS exclusive* design provides three levels of sealing for outstanding reliability! A double mechanical seal located inside the oil chamber provides two full levels of sealing. An additional V-Ring type lip seal between the oil chamber and pump volute provides a third, extra level of sealing, and enhanced mechanical seal protection.

SCAVENGER™ Effluent & Sewage Ejector Pumps

Effluent Pumps 1 1/4 & 2 Inch

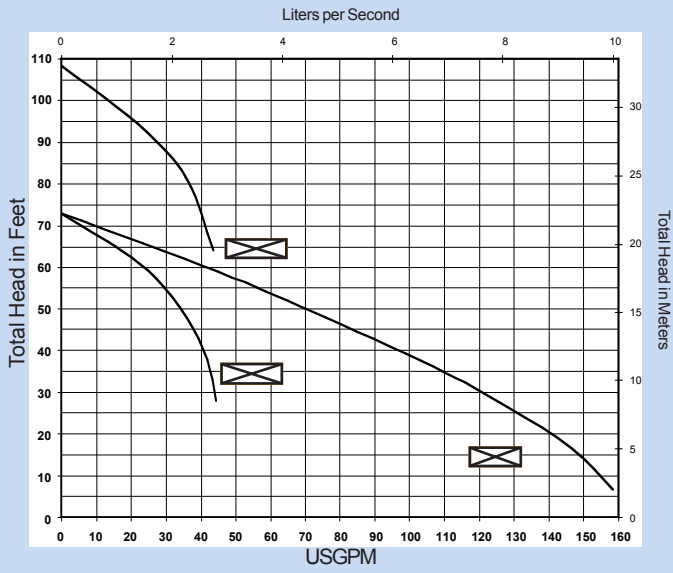

Sewage Ejectors, 2 Inch

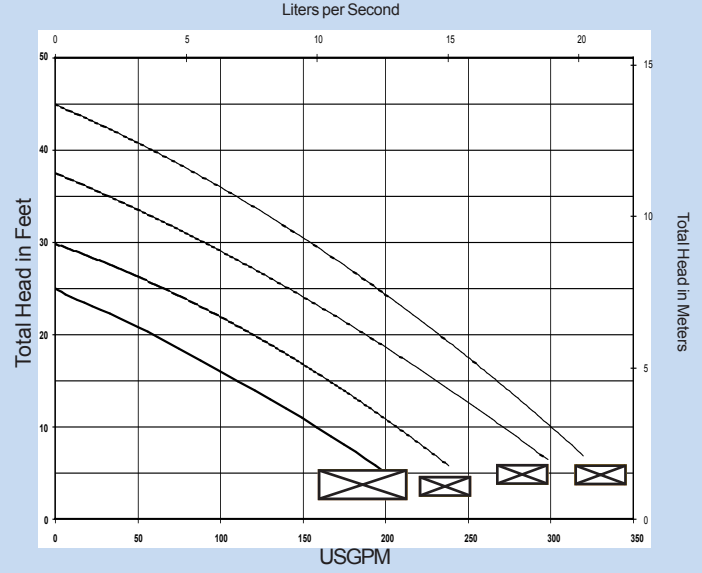

Sewage Ejectors, 3 Inch

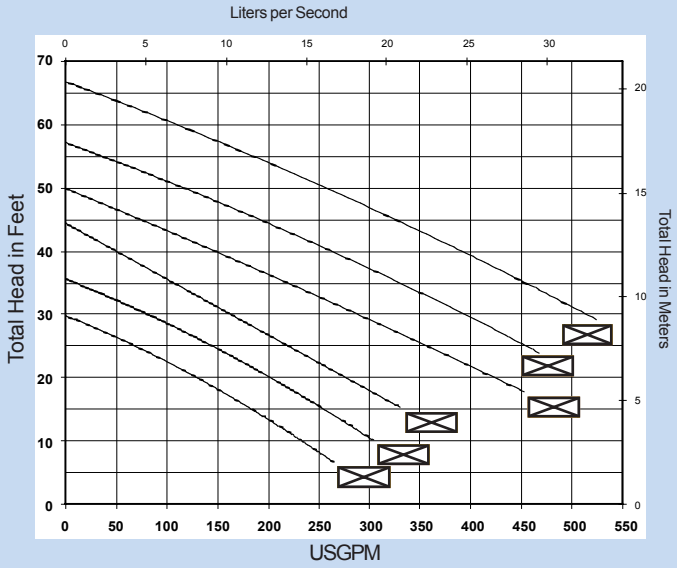

Sewage Ejectors, 4 Inch

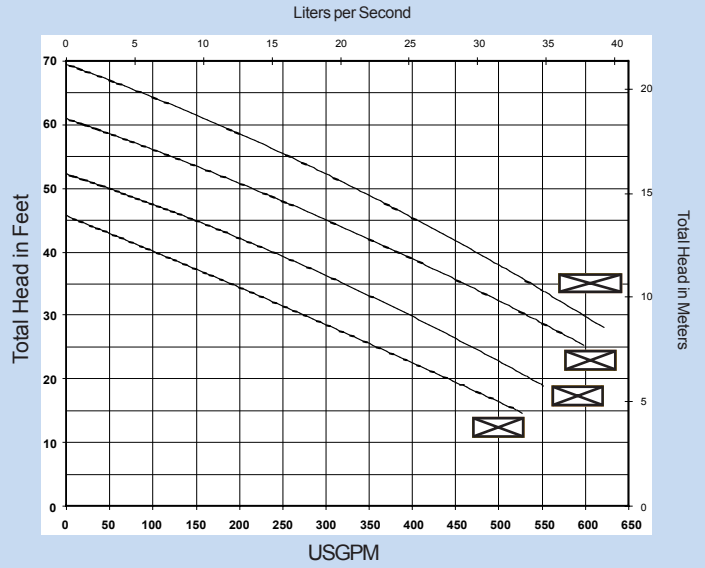

Example Applications:

Commercial

Airports
Apartments & Hotels
Bus & Train Terminals
Car Washes
Condominiums
Convention Centers
Hospitals
Office Buildings
Restaurants
Shopping Malls
Trailer Parks

Industrial

Factory Sewage
Garages
HVAC Condensate
Machine Effluent
Transfer Tanks
Washdown Tanks
Waste Treatment

Marine

Ballast Transfer
Bilge Dewatering
Bilge Transfer
Dry Docks
Fish Hatcheries

Residential & Municipal

Building Sumps
Home Sewage
Irrigation
Schools
Small Lift Stations
Water Features

Agriculture

Dairy Sewage
Irrigation
Tail Water Transfer

SCAVENGER™ Effluent & Sewage Ejector Pumps

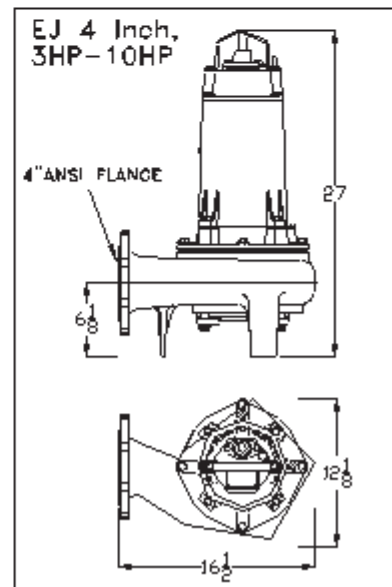
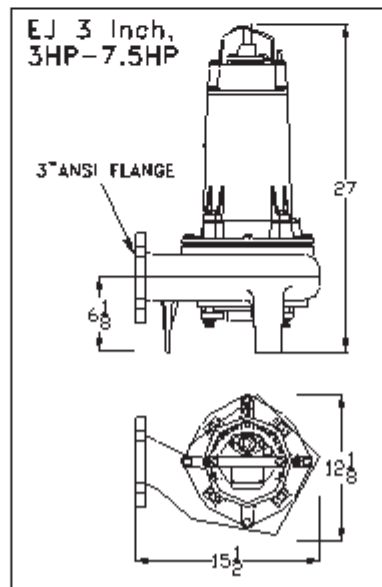
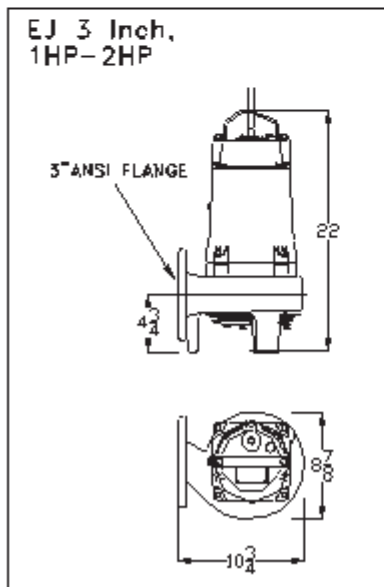
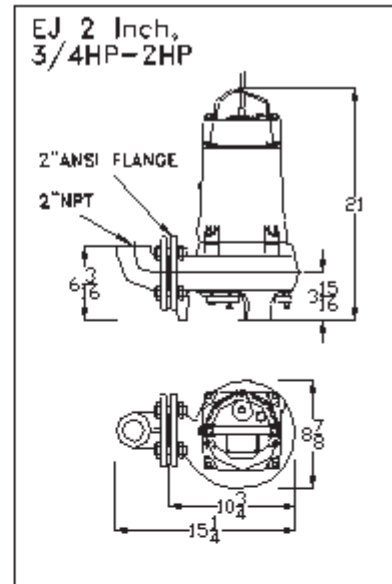
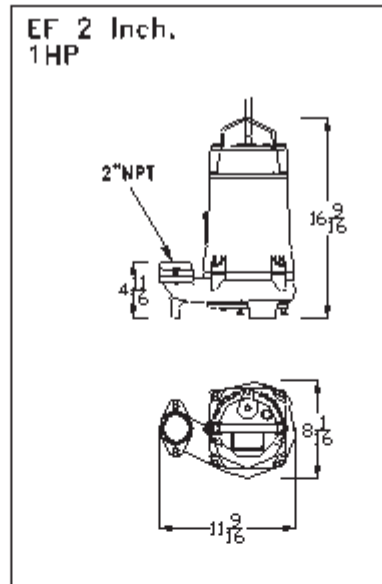
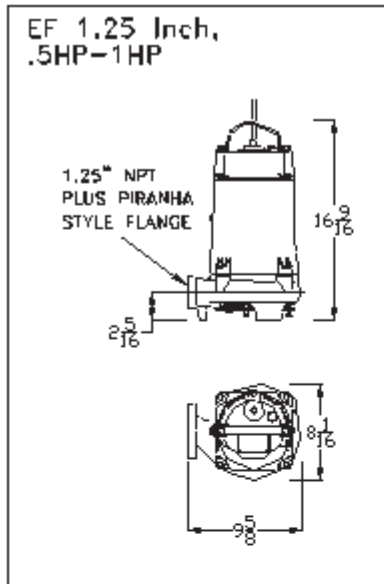

Corporate Office:
ABS Pumps, Inc.
140 Pond View Drive
Meriden, CT 06450
Tel: (203) 238-2700
Fax: (203) 238-0738

Regional Offices:
ABS Pumps, Inc.
111 Maritime Drive
Sanford, FL 32771
Tel: (407) 330-3456
Fax: (407) 330-3404

Odell's Pump & Motor Service
1650 Bell Avenue, Suite 140
Sacramento, CA 95838
Tel: (916) 925-8508
Fax: (916) 925-3914

ABS Dewatering
3849 N. Palmer Street
Milwaukee, WI 53212
Tel: (414) 964-3400
Fax: (414) 964-0677

ABS Pumps Corp.
1215 Meyerside Drive, Unit # 7
Mississauga, ONT L5T 1H3
Tel: (905) 670-4677
Fax: (905) 670-3709