



## Vertical Plate Pressure Filter VPA





## Mechanical Dewatering by Pressure

**As particles get finer the resistance against removing water increases. Gravity dewatering can no longer be used, pressure has to be used.**

**By creating a differential pressure  $D_p$  across a cake of solids, liquid can be removed by**

### **Compression**

“Dewatering by compression means replacing the liquid in a cake with particles”.

### **Through blow**

“Dewatering by through blow means replacing the water in a cake with air”.

For Vertical Plate Pressure Filters either compression or a combination of compression and air through blow is used.

The VPA Pressure Filter basically consists of a fabricated head stand and an end frame, joined by two side beams, which support the movable head (pressure piece) and the filter plates, which are fitted between the fixed and movable heads.

Pulling type hydraulic cylinders, 2 for VPA 10 size and 4 for VPA 15 and VPA 20 size filters, are used to open and

close the filter and to provide the necessary closing force during filtration.

Filter cloths are suspended from tubular supports and hang between the filter plates. The cloth support bars are carried on an upper frame to which vibrator motors are fitted. These can be activated during cake discharge to ensure full removal of cake from the cloths.

The filter plates are linked together and to the movable head, so that the filter plates are opened “concertina” style and to provide accurate spacing between the plates during opening. Similarly the cloth support bars are also linked together to ensure that the cloths are always located between filter plates.

The filter cloth support bars also serve as spray pipes, being fitted with spray nozzles and being fed from a fixed header pipe and flexible hoses. As the spray nozzles are located between the filter cloths, the cloth wash water is contained between the cloths and over spray is eliminated.

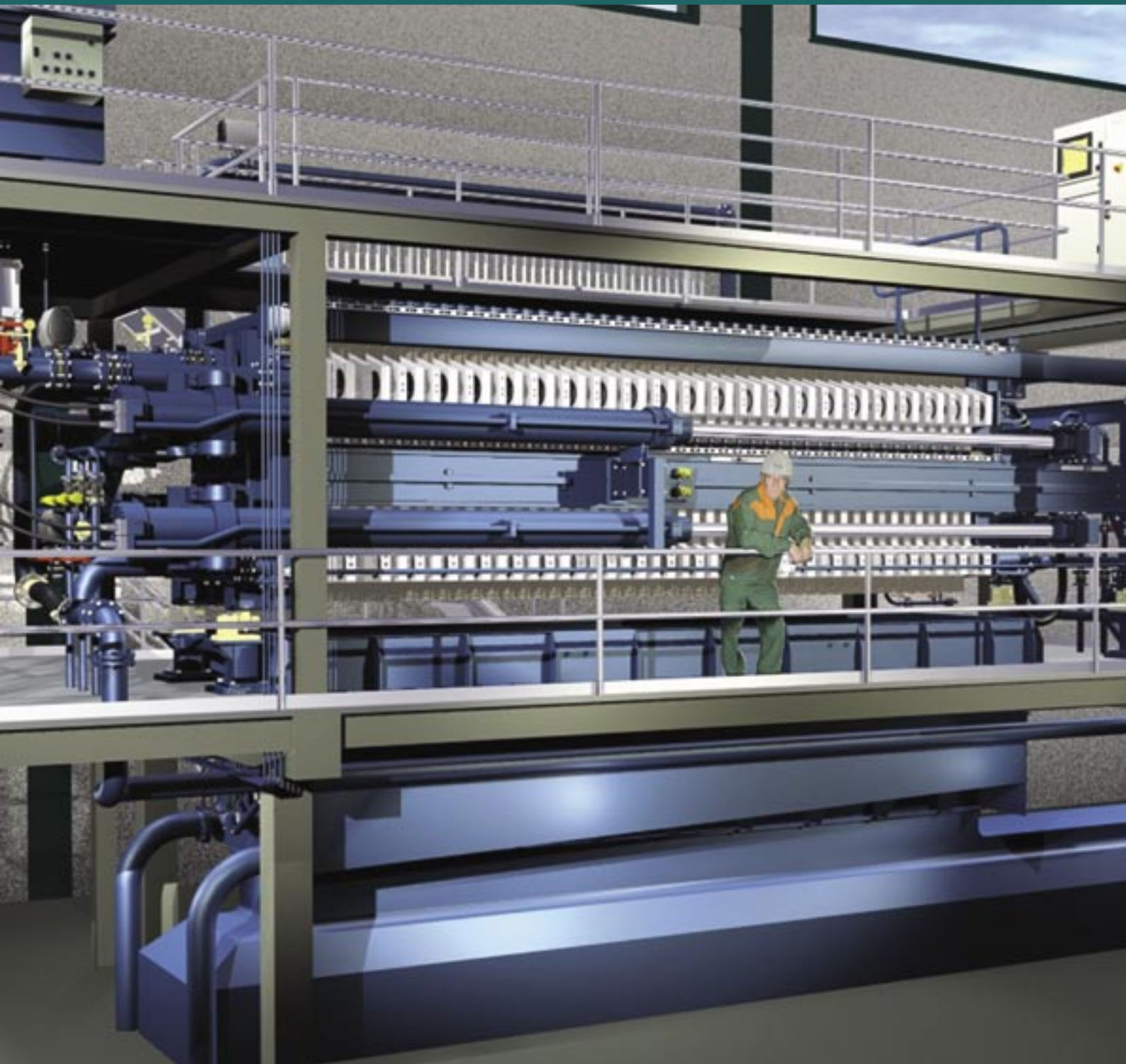

**The heart of the system is the Pressure Filter which is available in two basic versions VPA and VPC.**

VPA means Vertical Plate Airblow and designates the filter which provides for compressed air dewatering of the filter cake.

The operating pressure of this machine is usually 7-10 bar and is the standard machine for dewatering of mineral concentrates. Membranes are inflated with compressed air. Cycle time can often be as short as 6 minutes.

VPC means Vertical Plate Compression and designates the filter which provides for high pressure membrane dewatering of the filter cake.

This machine can operate with pressures up to 16 bar and is used where high pressure filtration and membrane pressing is required for dewatering.

The field of applications is wide and ranges from very fine particle slurries in the industrial mineral industries to precipitated sludges in the chemical industry. Membranes are inflated with high pressure water. Cycle time often varies from 10-30 minutes depending on application.

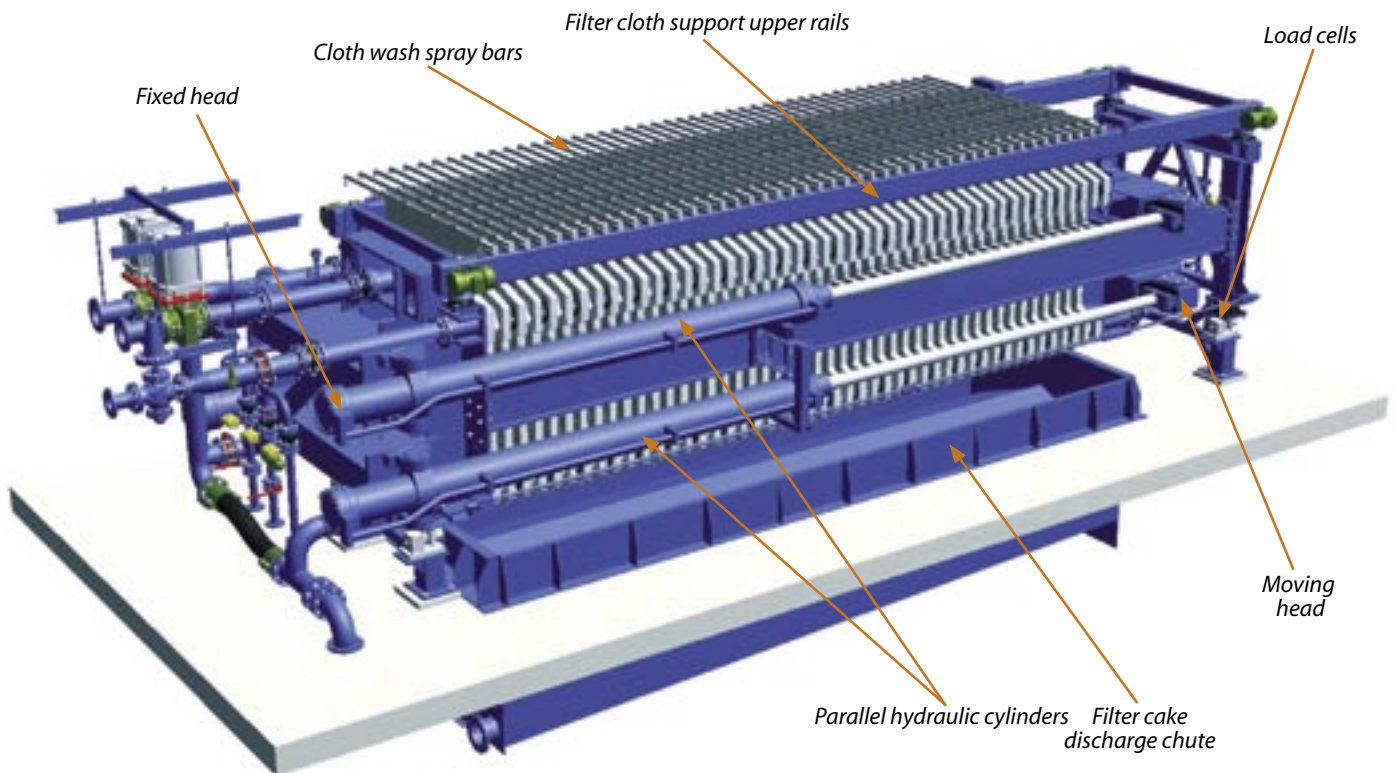

## The Vertical Plate Pressure Filter

Development in filtration and dewatering technology has advanced rapidly in the last years. Environmental awareness has been a major driving force and increase in cost of energy and personnel has made tougher demands on efficiency and automation.

Metso now launches the next generation of the VPA including the "JUMBO", with capacities in excess of 250 tonnes per hour in a single unit.

The basis of this development has been the requirement of the heavy industry for reliable automatic operation and simple maintenance.

Metso developed the VPA pressure Filters for the mineral industries which brought together high performance and high degree of automation into lowest total cost.

The result is an Automatic Pressure Filter with unique features such as:

- Light weight construction with machined polypropylene filter chambers.
- Compact design with pulling hydraulic cylinders for reduced space requirement.
- Filter Cloth change, a one minute operation.

- Available in several pressure ratings for different applications.
- Few moving parts for low maintenance and high availability.

The complete filtration system must be carefully considered for each individual application. Metso supplies the complete system:

- Slurry thickener with automatic discharge
- Feed slurry buffer tank
- Flow and density meters for filter feed
- Slurry feed pump
- Cloth wash water pump and tank
- Compressed air system
- Product weighing system for production monitoring
- Filter cloth damage detector
- Process controller for complete automatic operation
- Service platform



## VPA - Features and Benefits

- Simple construction with few moving parts
- Pulling cylinders provide a compact layout and light weight support frame design
- Plastic (Polypropylene) filter plates, for good chemical resistance and light weight
- Fully automatic control system with load cells and patented weighing system for process control.
- Fixed hanging filter cloths with few moving parts, makes low maintenance costs.
- Fast and easy cloth changing
- The VPA-membrane technology means low energy requirements = low dewatering costs.
- The VPA pressure filter is originally developed for use in dewatering of minerals and mineral tailings. Most other filters are developed for other materials (mostly organic) and rebuilt for use in minerals.
- Because of few moving parts the VPA filters have low spare- and wear parts costs, often less than 50% compared with other filters.
- The VPA membrane technology eliminates drying cracks in the cakes which means lower compressed air consumption = lower dewatering costs. Other membrane systems do not allow membrane squeezing at the same time as air drying.
- Some filters on the market must select suitable filter cloths for both filtration- and mechanical reasons, which dramatically reduces the assortment of available filter cloths. With the VPA concept the best cloth for filtration only, can be selected.

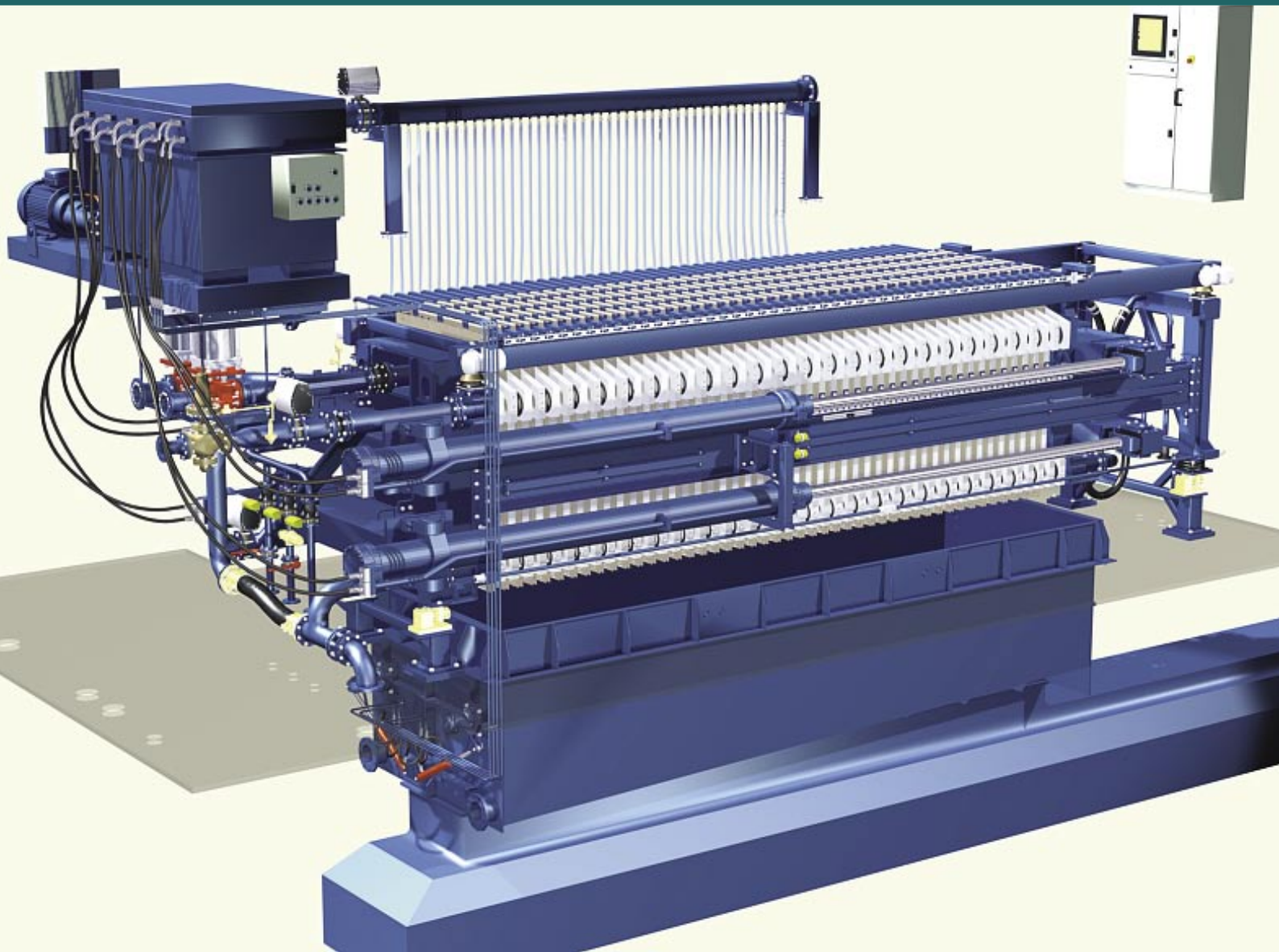

### **Simple Mechanical Construction**

The Metso Pressure Filter is a heavy duty machine, developed for filtration of metallic minerals, industrial minerals, coal and tailings.

The filter has simple mechanical construction and design, with few moving parts.

By using a pulling hydraulic cylinder system for closing and sealing the filter plate pack, we can provide a compact layout and a light weight support frame design.

Polypropylene filter plates are used for good chemical resistance and the light weight.

### **Low Dewatering Cost with the Membrane Technology**

The Pressure Filters use a rubber membrane in each filter chamber. The membrane technology eliminates cracks in the cakes and also compensates for the shrinking in the cake during the compressed air drying. The result means lower compressed air consumption and lower total dewatering cost.

### **Low Maintenance Cost**

Because of the simple mechanical design with few moving parts as well as the filter cloth design and system, with extremely short downtime for cloth changing, the Metso Pressure Filters have very low maintenance costs.

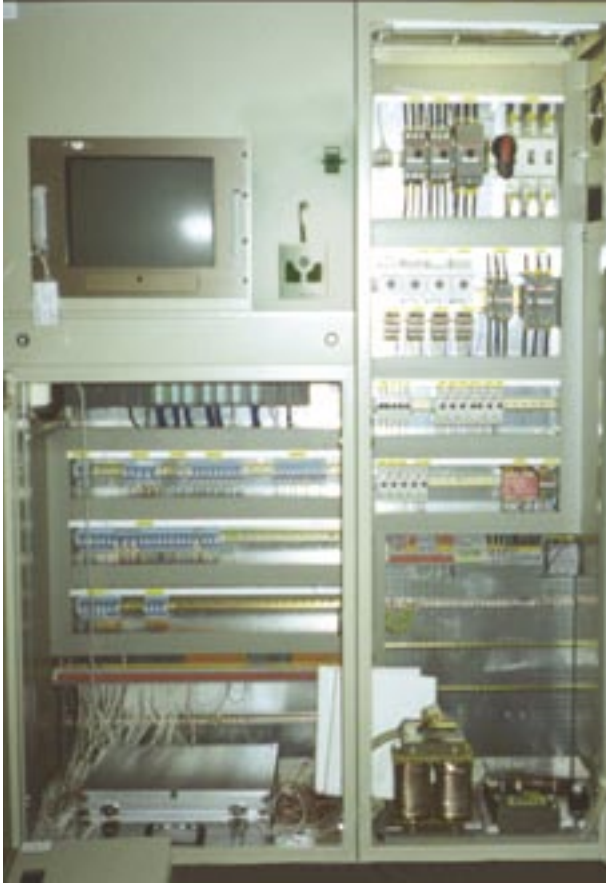

## Smart Fully Automatic Control System

The Pressure Filter is controlled by a system consisting of a PLC connected to a PC screen, built in a well sealed and well insulated cabinet. All control logics are implemented in the PLC. On the PC monitor the filter operator can follow and control the filter operation and information such as settings, statistics and alarms.

## High Unit Capacity

By installing the Metso Pressure Filter on load cells connected to the PLC a multitude of data become available. The weighing system provides accurate production information, and can be used to optimise the filtration- and drying steps in the filter cycle.

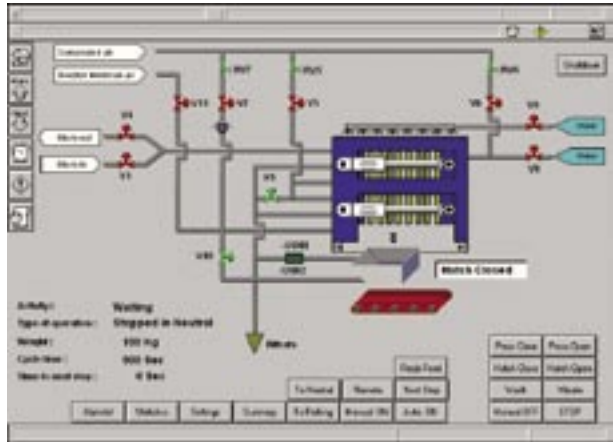

## Dimensions

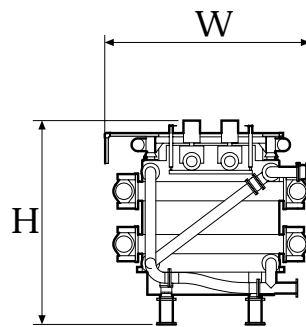
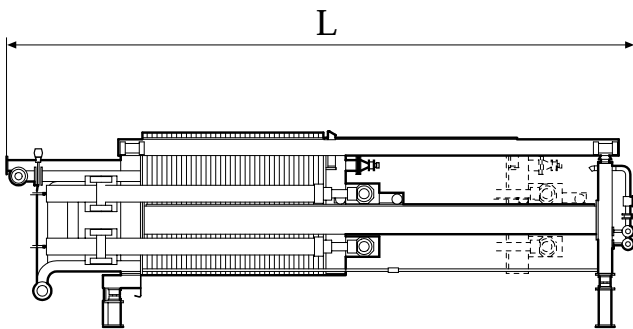

The complete Metso VPA or VPC Pressure Filter installation can be arranged in several ways and the table below is for guidance only. Detailed installation drawings are available from Metso and are issued with quotations or upon request.

Size	L <sub>min</sub>	L <sub>max</sub>	H	W
VPA 10 No. of chambers	5400 (212) 12	9600 (378) 40	2355 (93)	2750 (108)
VPA 15 No. of chambers	7850 (309) 16	3650 (537) 60	3160 (124)	3800 (150)
VPA 20 No. of chambers	9800 (386) 20	16150 (636) 50	4580 (180)	4250 (167)

All dimensions in mm (inch)

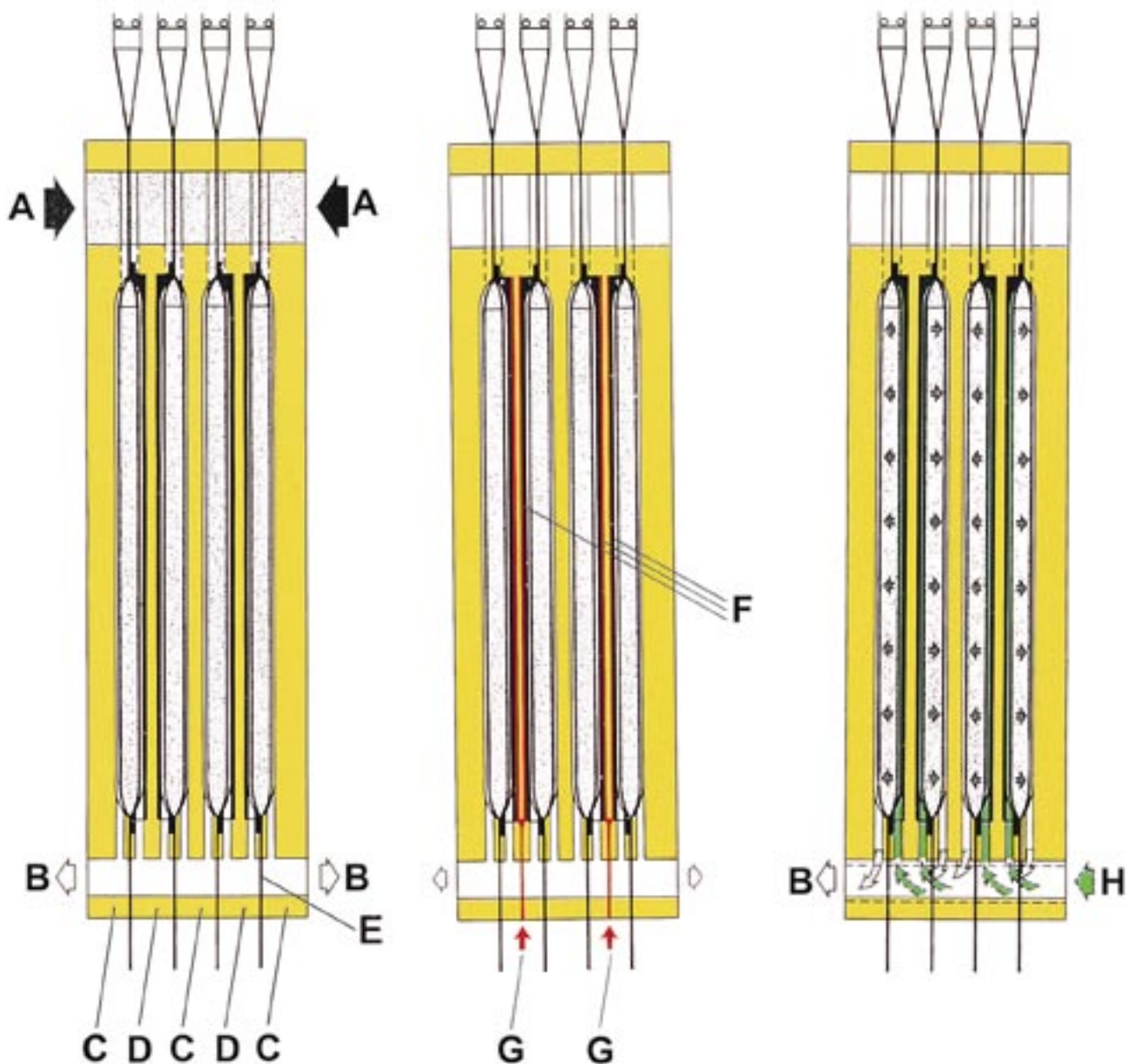

## Filtration

The pressure filter plate pack is locked under pressure by the high pressure hydraulic pump. Feed slurry enters the filter chambers through the top-feed ports. Filtration begins immediately on both sides of the chamber. The filtrate is drained through the four ports of each chamber. The double sided filtration gives speedy build-up of the filter cake and a short filtration part of the cycle.

Filtration begins immediately on both sides of the chamber. The filtrate is drained through the four ports of each chamber. The double sided filtration gives speedy build-up of the filter cake and a short filtration part of the cycle.

- A. Slurry feed
- B. Filtrate
- C. Filter plate
- D. Membrane plate
- E. Filter cloth

## Compression

When the cake is formed it is stabilized by inflating the rubber membrane on one side of each cake. This is normally a short part of the cycle and is beneficial for the dewatering economy and reduces the total cycle time.

Membrane inflation is accomplished by compressed air or, for high pressure applications, by pressure water.

- F. Diaphragm
- G. Pressure medium (air or water)

## Air Dewatering (VPA)

Compressed air is supplied to the membrane side of the filter cake and displaces the free water in the cake to the filtrate discharge on the opposite side of the cake. The membrane is usually kept inflated to maintain good cake stability.

This reduces air consumption and ensures lowest residual cake moisture. The time for air blow depends on the material to be dewatered but is typically 1-4 minutes.

- H. Compressed air
- B. Filtrate

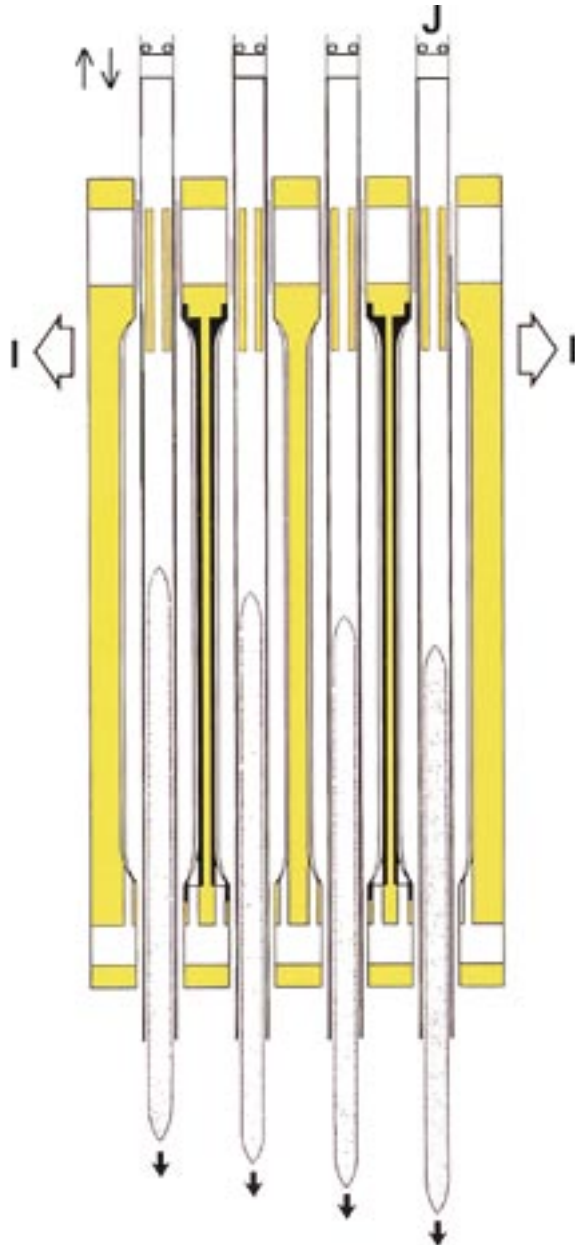

## Cake Discharge

When the cakes are ready for discharge the cake chute door (drip tray) is retracted and the filter opened by actuating the high capacity hydraulic pump. The filter opens at a rate exceeding one chamber per second.

The cloths hang freely from the suspension bar and the cakes are released at the same rate. In the fully open position the cloths are vibrated (if necessary) to ensure release of any cake residue. This is controlled by the load system.

I. Chamber opens

J. Cloth vibration

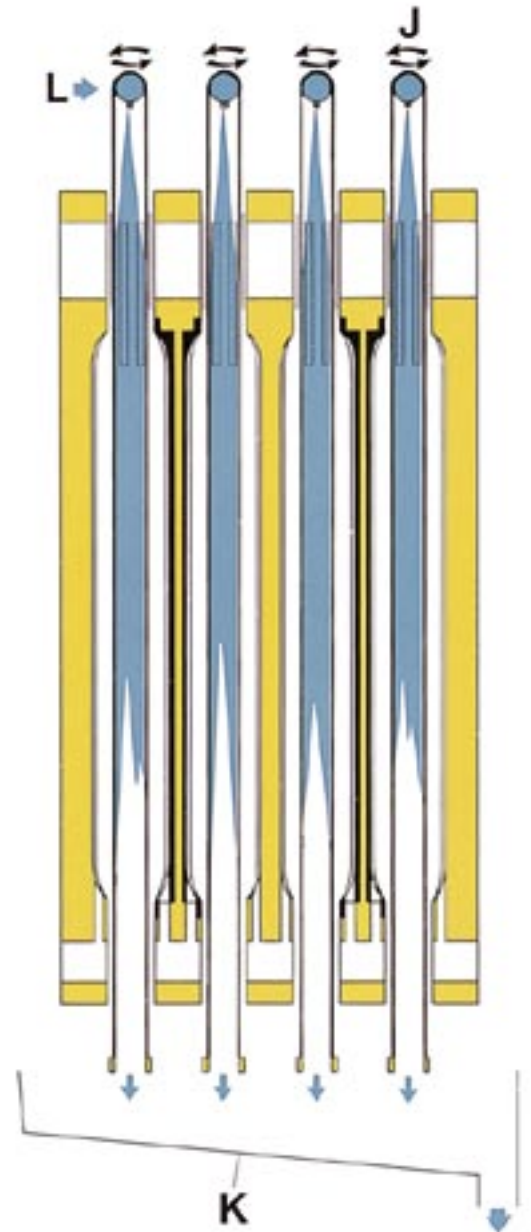

## Cloth Washing

With the plate pack still in the open position the cake chute door (drip tray) is closed and the cloths are rinsed by the spray nozzles in the cloth suspension bars. The cloth vibrators may be actuated during the cloth washing.

This sequence takes about 30 seconds and after this the filter is closed and the cycle begins again.

K. Drip tray in position

L. Washing cloth from internal spray bar

J. Cloth vibration

## Minerals Processing

**Our ranges:** **Grinding Mills**  
**Flotation Machines**  
Reactor Cell Systems  
DR Flotation Machines  
Flotation Columns

**Classifiers**  
Spiral Classifier  
**Mixers**  
Agitators  
Attrition Scrubbers

**Magnetic Separators**  
Low Intensity Magnetic  
Separators  
High Gradient Magnetic  
Separators

**Sedimentation Equipment**  
Inclined Plate Settlers  
Thickeners & Clarifiers  
Spiral Dewaterers

**Filtration Equipment**  
Vertical Plate Pressure  
Filters  
Tube Presses

### **Metso Minerals (Brasil) Ltda.**

Av. Independência, 2.500 Éden  
18087-050 Sorocaba  
SP  
Brazil  
Phone: +55 15 219 1300  
Fax: +55 15 219 1699

### **Metso Minerals (Chile) SA**

Avda Vitacura 4380, 5th floor  
Vitacura, Santiago  
Chile  
Phone: +56 2 3702000  
Fax: +56 2 3702039

### **Metso Minerals Industries Inc.**

P.O. Box 15312, York  
Pennsylvania, 17405-7312  
USA  
Phone: +1 717 843 8671  
Fax: +1 717 845 5154

### **Metso Minerals (Sala) AB**

SE-733 25 Sala  
Sweden  
Phone: +46 224 570 00  
Fax: +46 224 169 50

### **Metso Minerals Canada Inc.**

1197 Ballantry Road  
Oakville, ON L6H 5M7  
Canada  
Phone: +1 905 337 8811  
Fax: +1 905 337 8827

### **Metso Minerals (UK) Ltd**

2 Lindenwood  
Crockford Lane  
Chineham Business Park  
Basingstoke  
Hampshire RG24 8QY  
UK.  
Phone: +44 (0) 1256 376200  
Fax +44 (0) 1256 376221

### **Metso Minerals (Johannesburg) (Pty) Ltd**

Private Bag X2006  
Isando, Johannesburg, 1600  
South Africa  
Phone: +27 11 397 5090  
Fax: +27 11 397 5826

### **Metso Minerals Asia Pacific**

Locked Bag 10,  
Blacktown BC, NSW 2148  
Australia  
Phone: +61 2 8825 1600  
Fax: +61 2 8825 1799

**www.metsominerals.com**  
**E-mail: minerals.info@metso.com**

