

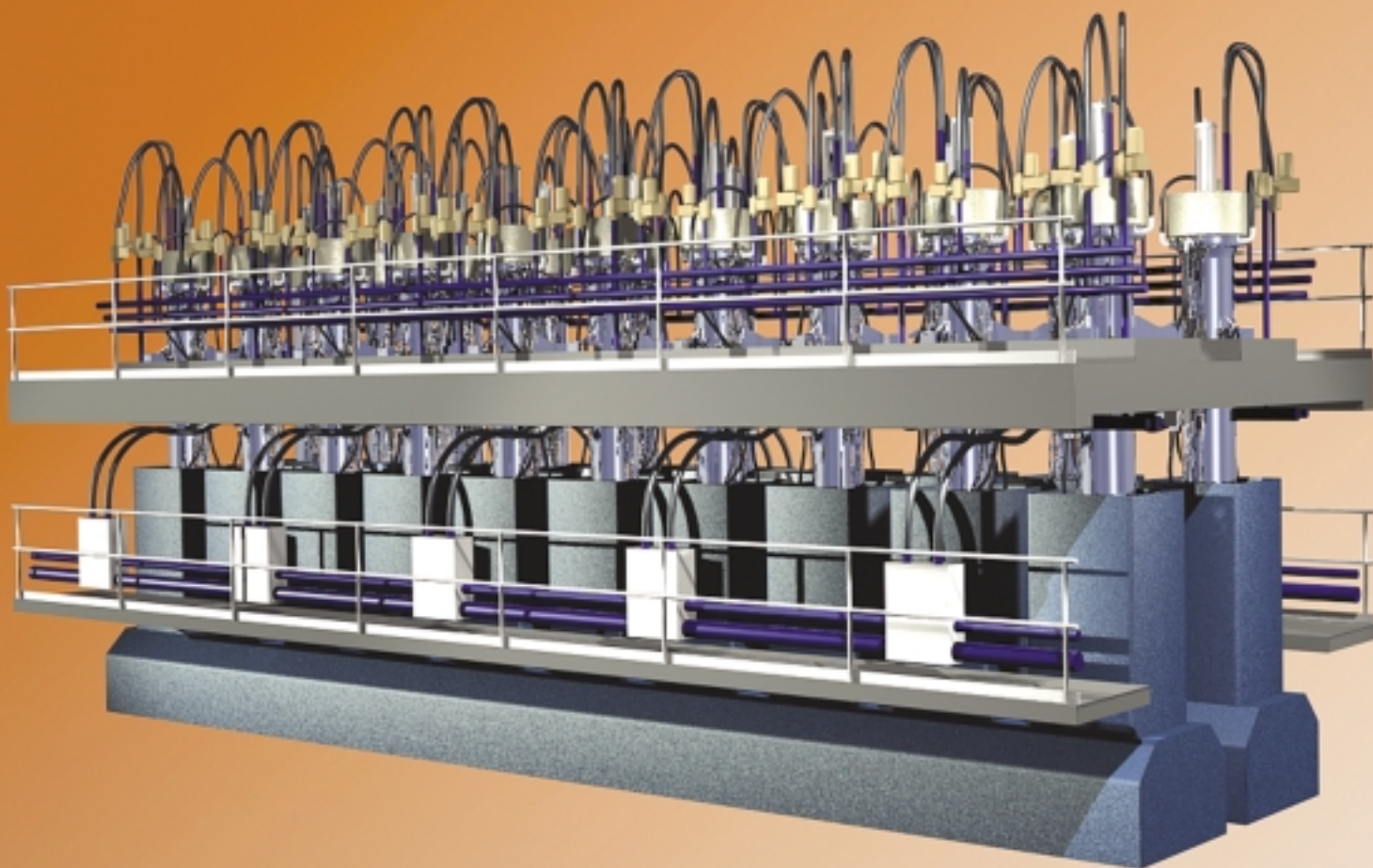

## Tube Press





## Tube Press

### Introduction

**The Tube Press is a membrane type filter press designed in cylindrical format and capable of operating at high filtration pressures up to 140 bar. The use of these high pressures enables a higher degree of separation of the liquid and solid phases. The Tube Press is suitable for applications:**

- Where the process requires very low cake moisture. eg. smelters
- Where cake handleability is critical. e.g. underground slimes
- Where filtrate is a valued product
- Where cake transport costs are significant
- Where cake is to be disposed of to landfill

### Principle of operation

Filtration takes place between two concentric cylinders. The outer cylinder is the casing, and the inner, the candle.

The process slurry is pumped into the annular space between the filter media and the bladder. Hydraulic fluid,

usually water, is then pumped between the bladder and the casing putting the slurry under pressures and causing filtration to take place. When filtration is complete the hydraulic fluid is withdrawn from the Tube unit using vacuum until the bladder is dilated against the casing.

The candle is then lowered to the discharge position and a pulse of air is blown between the candle and the filter media. This causes the filter cloth to expand, fracturing the cake which is discharged under gravity. When complete the candle closes to the slurry fill position to repeat the cycle.

Air purge and/or cake wash can be incorporated into the cycle. At the completion of the filtration element, air or wash fluid is pumped between the cake and the bladder which is then forced through the cake by a further application of hydraulic pressure to be incorporated into the cycle.

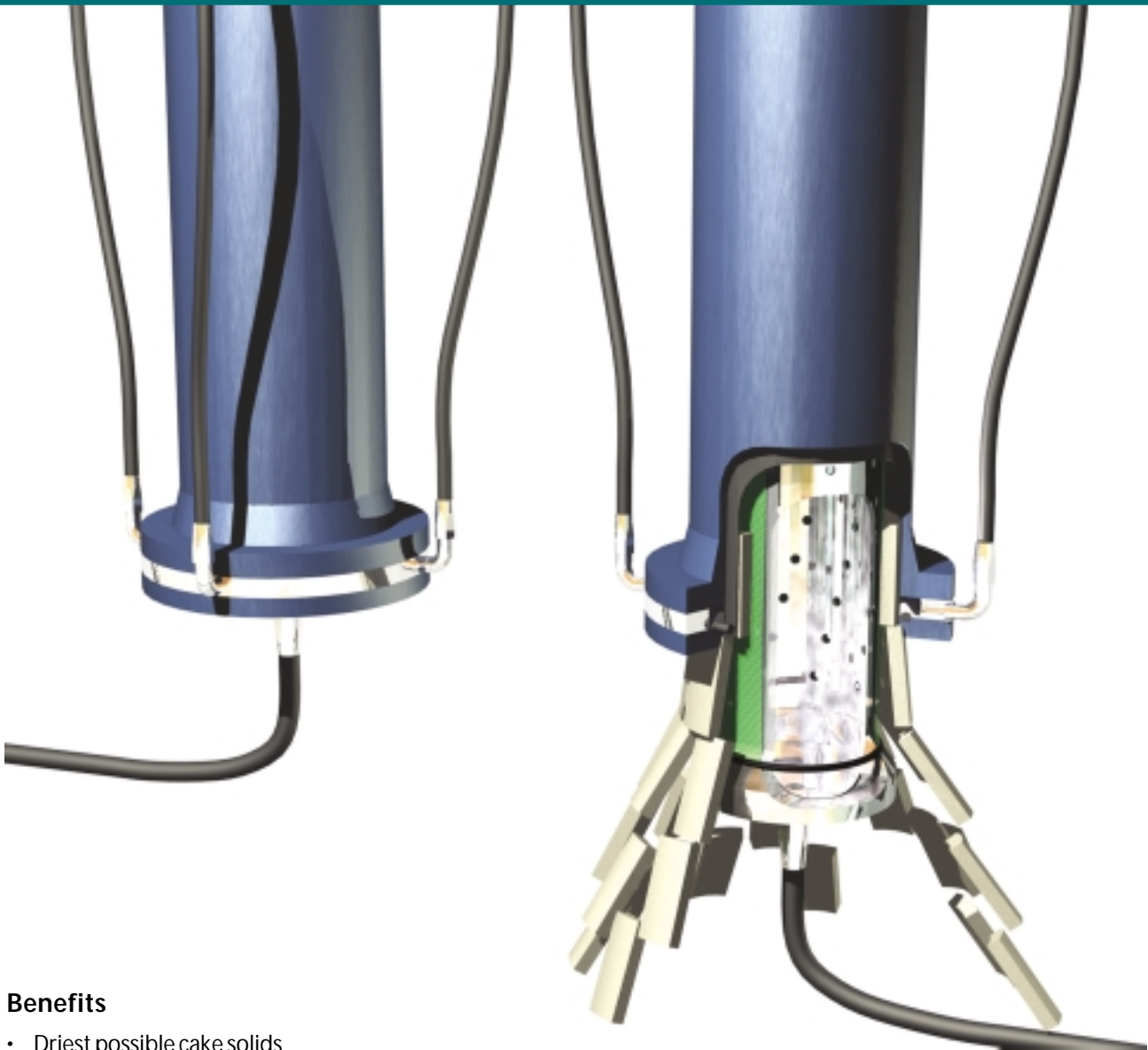

## Benefits

- Driest possible cake solids
- Maximum volume reduction
- Exceptionally clear filtrate

## Advantages of On-Site Tube Press

Tests will be undertaken on production slurry and will encounter any variability of production feed that occurs during the trial. The client will see the performance and in particular will be able to handle the cake and observe the filtrate clarity.

The client has opportunity to operate the plant.

Contact your Metso representative for further information on these available services.

## Reliable Support

Metso specialists are experts in a wide range of industrial processes. Our policy is to provide a thorough knowledge of our customers' applications.

## Research and Development

It is Metso's policy to continue to improve, thus the performance of new materials is assessed with a view to greater efficiency and reliability.

## After Sales Service

Our after sales service provides you with fully detailed operating and maintenance instructions, training, professional start-up services and technical assistance.

## Opportunities

In many industries a liquid phase in the process creates the need for liquid/solid separation so that the solids and/or filtrates so produced can be handled or disposed of.

"Traditional" mechanical dewatering often leaves the cake too wet or too sticky to handle effectively and usually demands further treatment such as thermal drying.

The Tube Press, because of its unique design, will automatically and economically dewater most slurries to produce a clear filtrate and, without any form of thermal drying, a hard, surface dry cake that is convenient to handle as a product for immediate storage or for disposal.

### Typical Tube Press Flowsheet

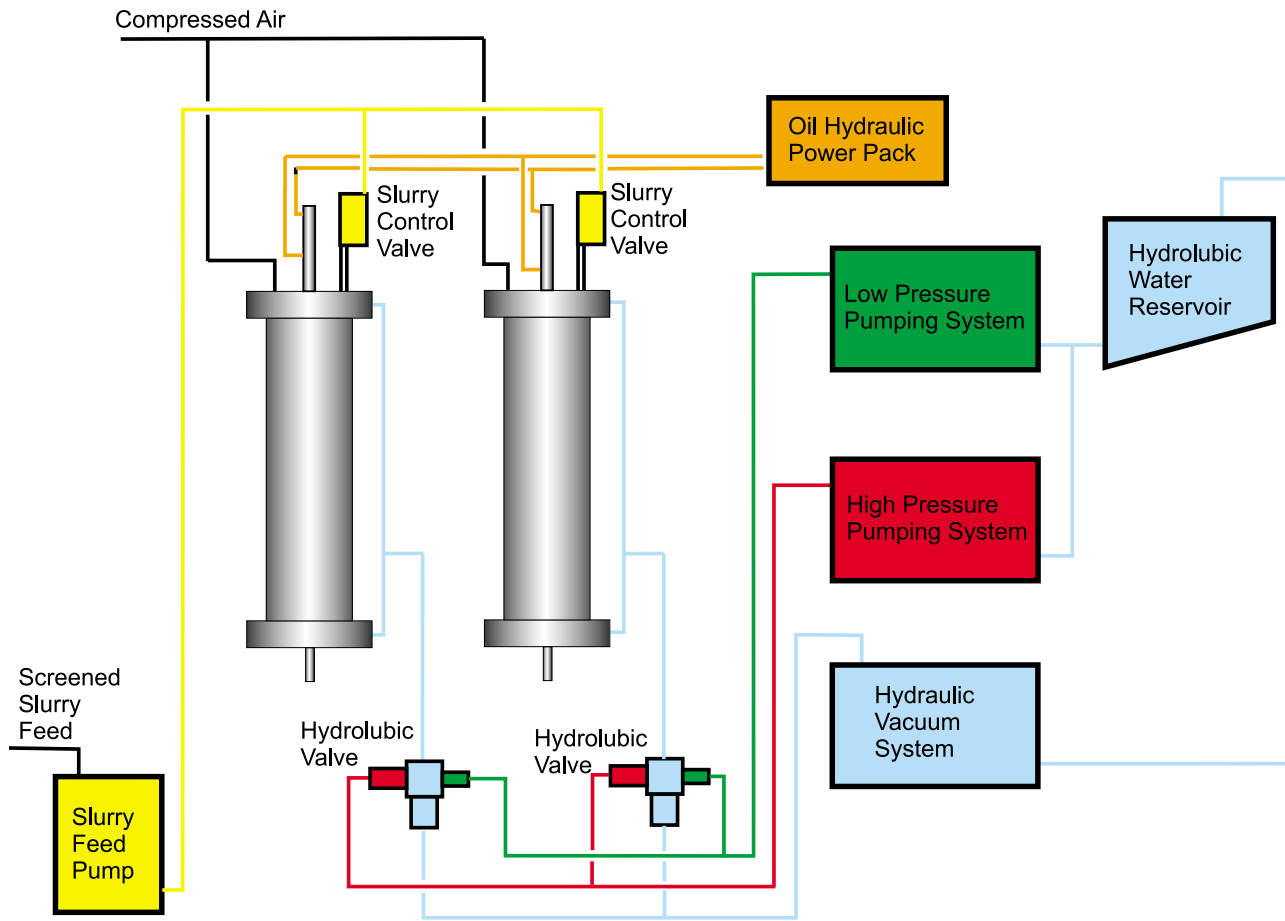

Two Tube Module inclusive of ancillary pumps and hydraulic water systems.

### The Tube Press Process

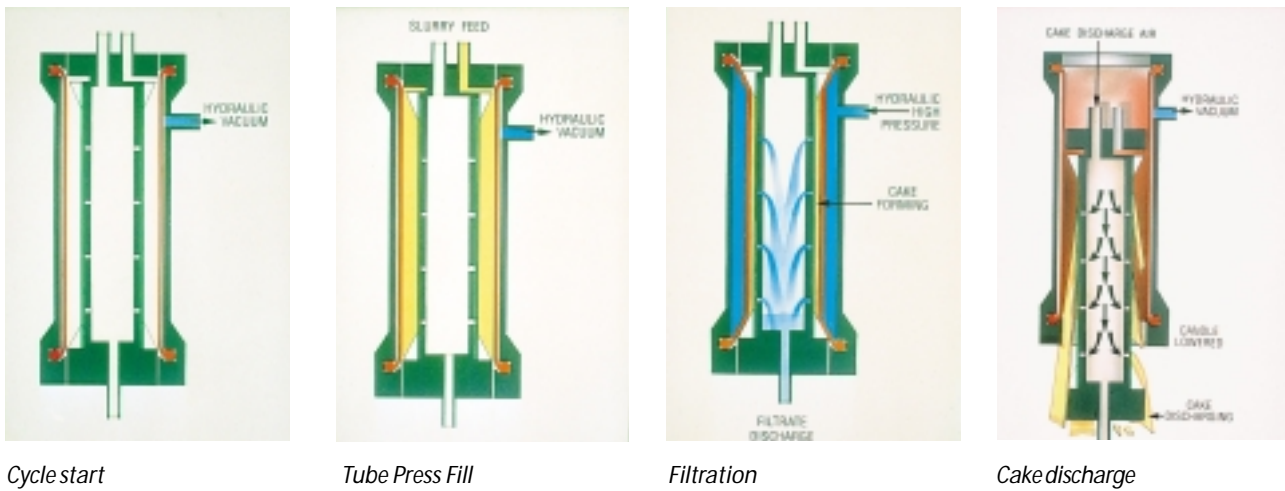

## Applications

### Typical filtercake moisture contents

Coal fines and shales	19%
Calcium carbonate precipitates	30%
Gypsum residues	14-18%
China clay	15%
Iron oxide fume	28%
Quarry clay slimes	19%
Seawater magnesia	27%
Lead chromate retrieval	22%
Zeolites	41%
Furnace/Converter	15-18%
Ferrites	14%
Jarosite	22%
Titanium Dioxide	20%
Magnesite	23%

Dyestuffs/Pigments	20%
Para-goethite	27%
Metal Sulphides	13%
BOS Sludge	15%
Oxalates	14%
Molybdenum	10%
Zinc Concentrate	12%
Copper Concentrate	12%
Tin Concentrate	10%
Gold Concentrate	21%
Nickel Concentrate	10%
Silica Dioxide	50%

(\*Filtration Pressure 102 BAR).

### Superior Performance

Porosity and cake moisture contents are significantly lower than those obtained with low pressure filters, consequently filtrate recovery is high.

Filtration is conducted at a pressure level where the cake is produced as a hard surface dry, lump solid. Cake handling procedures are greatly simplified compared with those for low pressure filter cakes, which are typically plastic or paste-like and frequently surface wet.

Available data indicates that Tube Press output rates, in terms of dry solids per unit filter area, are much higher than for either vacuum or plate filter presses. This results both from the pressure dependence of filtration rates and the operational flexibility of the Tube Press which allows a closer approach to the optimum.

Filtrate solids concentrations are generally zero, allowing immediate disposal or direct recycling.



### Laboratory and Rental Service

Metso can filter your product on both a preliminary feasibility or on a full-scale production basis with either a lab-size unit or a production size Tube Press.

With well equipped laboratories, our experienced technicians will return a report, plus a small filter cake and filtrate sample to the customer for inspection.

It is **essential** that any sample provided for testwork is accompanied by details of its Safe Handling Requirements. If in doubt, the laboratory undertaking the tests will provide details of what is required under these regulations.

We can also provide Tube Press rental units for in plant testing. Each rig is essentially a fully operational single Tube Press plant, based around either a 500-series or 200-series Tube Press unit.

All rental units are complete with support structure, together with skid-mounted pallet, for ease of shipment and installation, containing the functional services required for operation. The control system on each rig will allow for automatic and manual operation.

Conventional filtration processes require continuous supervision and maintenance. The Metso Tube Press, however, is **fully automatic** which will yield **big savings** in manpower costs.

The Tube Press saves energy, lowers environmental impact and makes your process productive.

*Mobile test plant rig*

**Our ranges:** **Flotation Machines**  
Reactor Cell Systems  
DR Flotation Machines  
Flotation Columns  
**Classifiers**  
Spiral Classifier  
**Agitators**  
Mixers

**Minerals Processing**  
**Magnetic Separators**  
Low Intensity Magnetic  
Separators  
High Gradient Magnetic  
Separators  
**Sedimentation Equipment**  
Inclined Plate Settlers  
Thickeners & Clarifiers  
Spiral Dewaterers

**Filtration Equipment**  
Vertical Plate Pressure  
Filters  
Tube Presses

**Thermal Equipment**  
Holo-Flite® Processors

**Metso Minerals (Brasil) Ltda.**  
Av. Independência, 2.500 Éden  
18087-050 Sorocaba  
SP  
Brazil  
Tel. +55 15 219 1300  
Fax +55 15 219 1699

**Metso Minerals (Chile) SA**  
Avda Vitacura 4380, 5th floor  
Vitacura, Santiago  
Chile  
Tel. +56 2 3702000  
Fax +56 2 3702039

**Metso Minerals**  
SE-733 25 Sala  
Sweden  
Phone: +46 224 570 00  
Fax +46 224 169 50

**Metso Minerals**  
P.O. Box 340  
Colorado Springs, CO 80901  
USA  
Phone: +1 719 471 3443  
Fax: +1 719 471 4469

**Metso Minerals**  
4050 B Sladeview Crescent  
Mississauga, Ontario L5L 5Y5  
Canada  
Phone: +1 905 607 3330  
Fax: +1 905 607 3339

**Metso Minerals**  
Stocks House  
North Street  
Leatherhead, Surrey KT22 7AX  
United Kingdom  
Phone: +44 1372 81 43 00  
Fax: +44 1372 81 43 05

**Metso Minerals**  
Private Bag X2006  
Isando, Johannesburg, 1600  
South Africa  
Phone: +27 11 397 5090  
Fax: +27 11 397 5826

**Metso Minerals**  
Locked Bag 10,  
Blacktown BC, NSW 2148  
Australia  
Phone: +61 2 8825 1600  
Fax: +61 2 8825 1662

[www.metsominerals.com](http://www.metsominerals.com)  
E-mail: [minerals.info@metso.com](mailto:minerals.info@metso.com)

