

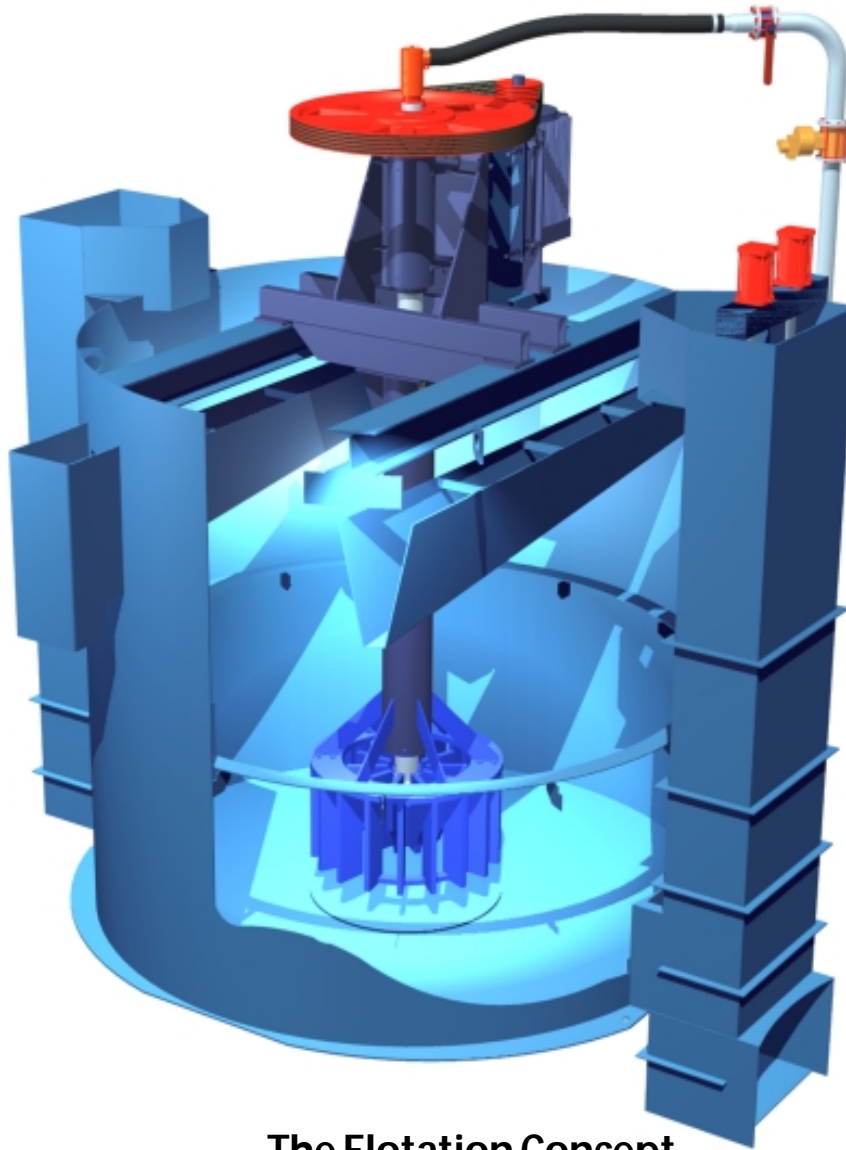

Flotation Machines RCS™





The Flotation Concept

The RCS flotation machine is the latest design to use the circular tank concept and combines the benefits of circular cells with the unique features of the mechanism to create the ideal conditions to maximise flotation performance for all roughing,

DV™ Flotation Mechanism

The patent-protected DV™ (Deep Vane) Mechanism impeller consists of a unique arrangement of vertical vanes with shaped lower edges and air dispersion shelf. The mechanism design produces powerful radial slurry pumping to the cell wall and gives strong return flows to the underside of the impeller to minimize sanding. Additionally it is the only mechanism to give maximum slurry recirculation to the upper part of the impeller. Vertical diffuser vanes promote these radial flow patterns and completely eliminate slurry rotation in the tank.

Enhances Flotation Performance:

- Maximum particle-bubble contacts within the mechanism and the flotation tank.

cleaning and scavenging duties.

Metso offers the full range of cell volumes required for modern ore processing plants with cell sizes from 5 to 200 m³.

- Effective solids suspension during operation and resuspension after shutdown.
- Effective air dispersion and distribution throughout the complete cell volume.

Reduces Operating Costs:

- Mechanism designed to minimize local high velocity zones within the impeller and diffuser to extend wear life.
- Impellers and diffusers are supplied in high abrasion-resistant elastomers or molded polyurethane.
- Impeller profile is designed to minimize absorbed power.

Ease of Maintenance:

- The DV mechanism is fully suspended from the cell superstructure and can be removed as a complete unit for routine maintenance.
- Wear parts can also be replaced within the flotation machine without removal of the mechanism.

Air Control:

- Flotation air is provided by a separate air blower.
- Aeration rate is manually or automatically controlled at each mechanism.

Proven Drive Systems:

- V-belt drive is standard up to 70m³ cell volume.
- Gearbox drive with extended output shaft bearings and drywell construction is standard for cell volumes over 70m³.

RCS™ Flotation Machine

The RCS™ (Reactor Cell System) Flotation Machine has been developed to combine the benefits of the circular cell concept with the unique features of the DV™ Mechanism to create the ideal conditions to maximize flotation performance for roughing, scavenging, and cleaning duties.

Maximum flotation recovery and performance have been achieved by careful attention to tank design.

- A very active lower zone for good solids suspension and transport, designed to maximize and create multiple particle-bubble contacts for recovery of the full range of particle sizes present.
- An upper zone with reduced turbulence to prevent particle-bubble separation of the coarser sizes.
- A quiescent cell surface to minimize particle re-entrainment.

Tank Design Features

- Circular tank concept with low level slurry entry and exit to minimize slurry short circuiting.
- Modular tank design to simplify construction, shipment and site installation.
- Cell superstructure designed to rigidly support the flotation mechanism and drive and to act as a support for both the drive maintenance platform and a walkway which extends across all cells in the flotation bank. Where environmental regulations apply, the complete cell top can be enclosed to minimize the release of ultrafine particles into the concentrator atmosphere.
- Wear protection is only required in the central area of the tank base, no protection is necessary at the tank wall.



Feed and Discharge Boxes

- Conventional feed, intermediate and discharge boxes are standard. Down flow control dart valves are located at the cell floor level.

Froth Handling

Each RCS™ tank is provided with double internal cross-flow launders for effective froth removal and minimal froth transport distance:

- Both launders discharge to one side of the cell to simplify froth handling.
- Froth crowder plates can be easily provided to reduce froth residence times for enhanced coarse particle and scavenger recovery.

Level Control

Pulp level control is by conventional pneumatically operated dart valves with float type or customer-specified level sensor.

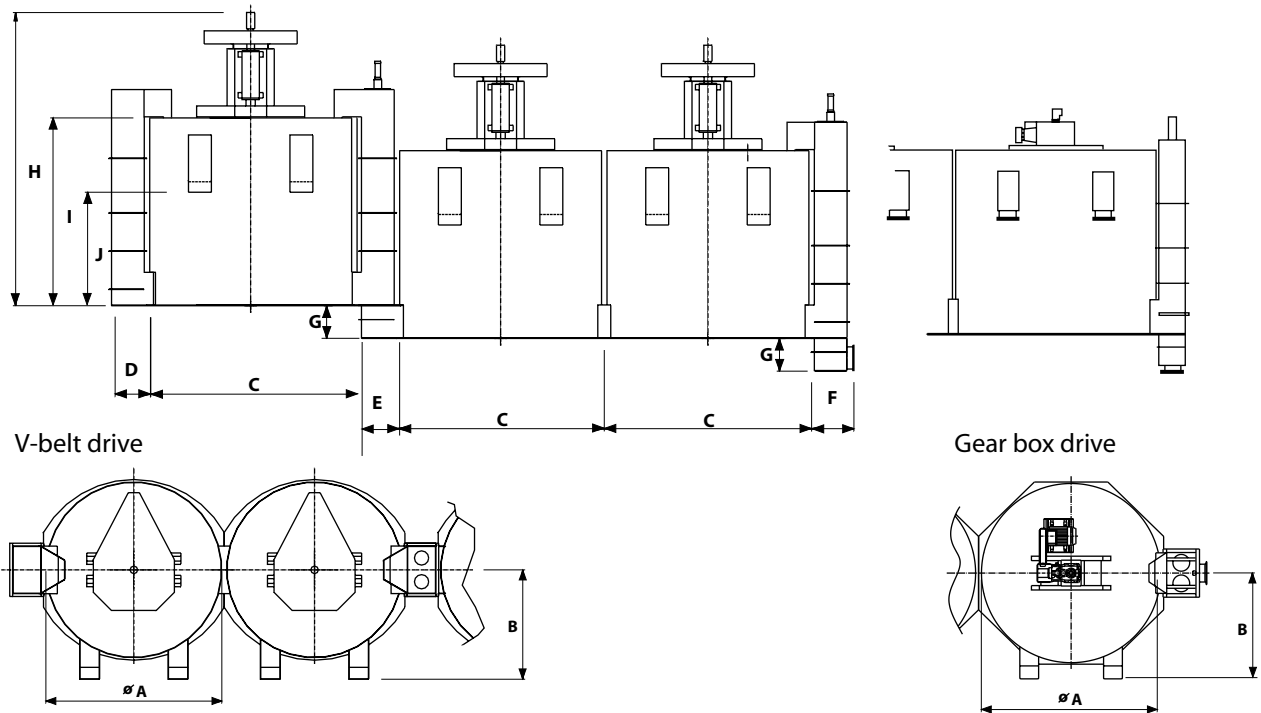

Cell Dimensions V-belt drive

	ØA*	B	C	D	E	F	G	H	I	J
RCS 5	2000	1230	2100	425	450	575	250	3020	2080	1295
RCS 10	2600	1550	2700	425	450	575	350	3610	2450	1465
RCS 15	3000	1820	3100	550	600	700	400	3990	2840	1755
RCS 20	3250	2050	3350	550	600	700	450	4610	3060	1765
RCS 30	3700	2300	3800	650	700	800	600	5375	3440	2070
RCS 40	4100	2360	4250	650	700	850	700	5780	3850	2370
RCS 50	4500	2615	4650	675	750	875	750	6100	4190	2495
RCS 70	5000	2950	5150	900	1000	1100	800	6690	4615	2830
RCS 100	5600	3300	5800	950	1100	1150	900	7510	5210	3355
RCS 130	6100	3600	6300	1150	1300	1400	1000	8250	5650	3515
RCS 160	6500	3850	6700	1150	1300	1400	1100	8925	6125	3995
RCS 200	7000	4100	7200	1350	1500	1400	1200	9375	6575	4300

Cell Dimensions Gear-box drive

	ØA*	B	C	D	E	F	G	H	I	J
RCS 100	5600	3300	5800	950	1100	1150	900	6510	5210	3355
RCS 130	6100	3600	6300	1150	1300	1400	1000	6875	5650	3515
RCS 160	6500	3850	6700	1150	1300	1400	1100	7495	6125	3995
RCS 200	7000	4100	7200	1350	1500	1400	1200	8050	6575	4300

*All dimensions in mm

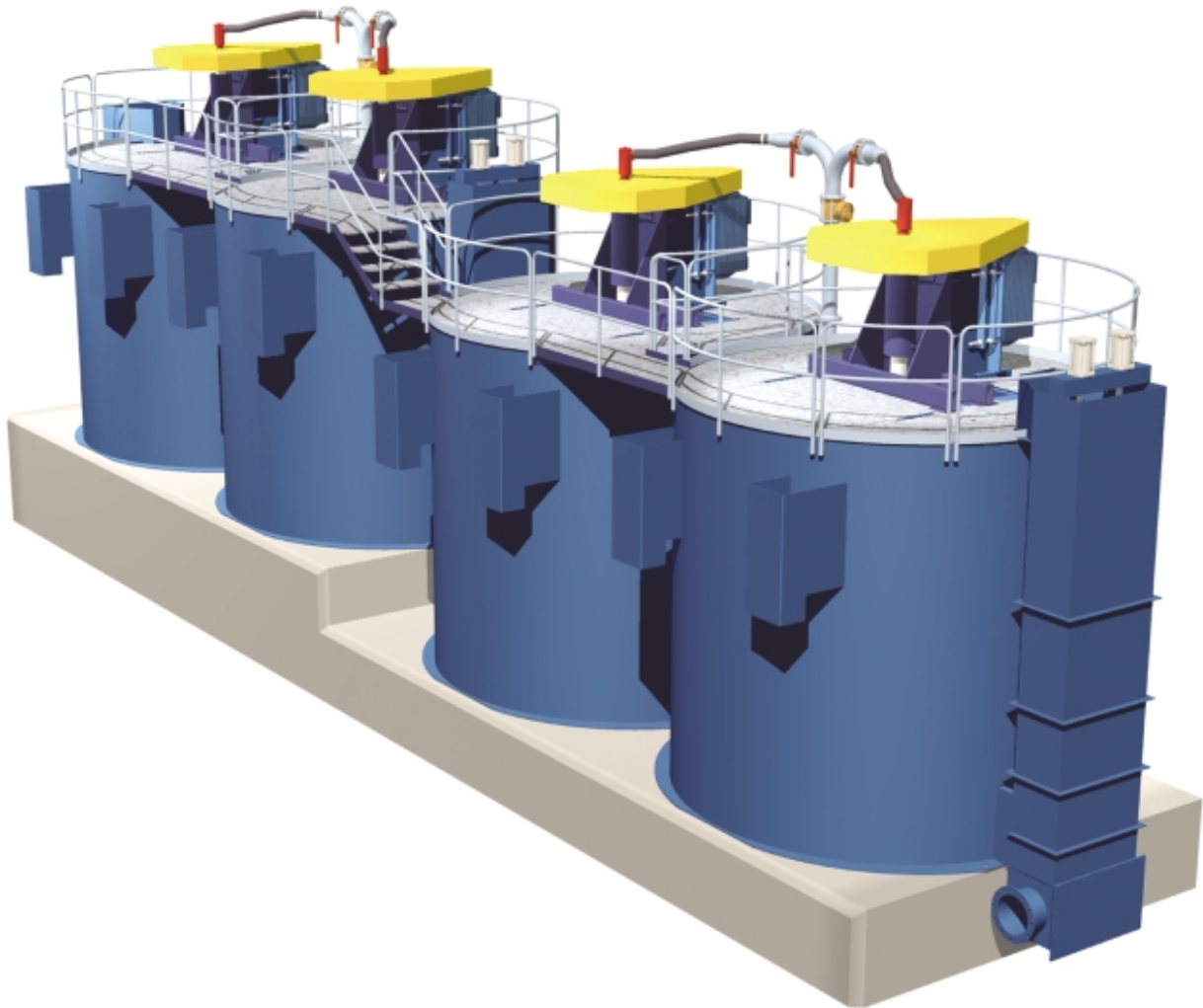

Specifications

		Cell Volume ⁽¹⁾		Connected Motor ⁽²⁾		Air Requirements ⁽²⁾			
		m ³	ft ³	kW	hp	m ³ /min	kPa	cfm	psi
RCS	5	5	175	15	20	3	17	110	2,5
RCS	10	10	355	22	30	5	22	180	3,2
RCS	15	15	530	30	40	7	25	250	3,6
RCS	20	20	705	37	50	8	27	290	3,9
RCS	30	30	1060	45	60	10	31	360	4,5
RCS	40	40	1410	55	75	12	34	430	4,9
RCS	50	50	1765	75	100	15	38	530	5,5
RCS	70	70	2470	90	125	18	42	640	6,1
RCS	100	100	3530	110	150	22	47	780	6,8
RCS	130	130	4590	132	200	27	51	960	7,4
RCS	160	160	5650	160	200	30	54	1060	7,8
RCS	200	200	7060	200	250	35	58	1240	8,4

(1) Effective volume (2) Per cell, slurry 1.35 S.G.

Metso Minerals Flotation Machines RCS™

Our ranges: **Flotation Machines**
Reactor Cell Systems
DR Flotation Machines
Flotation Columns
Classifiers
Spiral Classifier
Agitators
Mixers

Magnetic Separators
Low Intensity Magnetic
Separators
High Gradient Magnetic
Separators

Sedimentation Equipment
Inclined Plate Settlers
Thickeners & Clarifiers
Spiral Dewaterers

Filtration Equipment
Vertical Plate Pressure
Filters
Tube Presses

Thermal Equipment
Holo-Flite® Processors

Metso Minerals

SE-733 25 Sala
Sweden
Phone: +46 224 570 00
Fax: +46 224 169 50

Metso Minerals

P.O. Box 340
Colorado Springs, CO 80901
USA
Phone: +1 719 471 3443
Fax: +1 719 471 4469

Metso Minerals

4050 B Sladeview Crescent
Mississauga, Ontario L5L 5Y5
Canada
Phone: +1 905 607 3330
Fax: +1 905 607 3339

Metso Minerals

Stocks House
North Street
Leatherhead, Surrey KT22 7AX
United Kingdom
Phone: +44 1372 81 43 00
Fax: +44 1372 81 43 05

Metso Minerals

Private Bag X2006
Isando, Johannesburg, 1600
South Africa
Phone: +27 11 397 5090
Fax: +27 11 397 5826

Metso Minerals

Locked Bag 10,
Blacktown BC, NSW 2148
Australia
Phone: +61 2 8825 1600
Fax: +61 2 8825 1662

www.metsominerals.com
E-mail: minerals.info@metso.com

