

P O R T A B L E M I X E R S

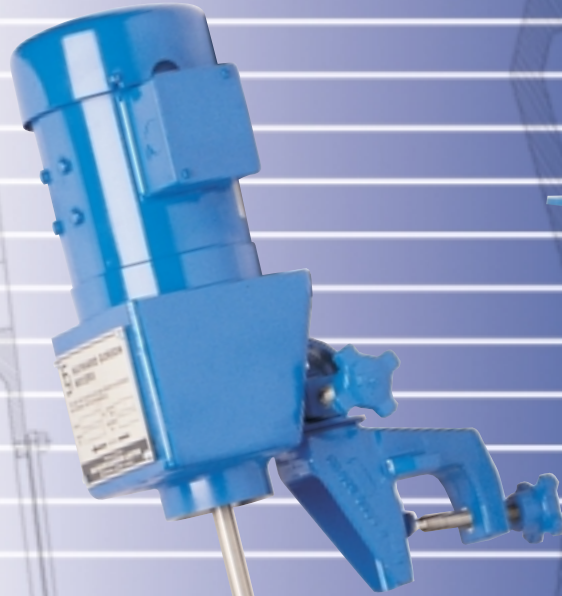

MIXERS

PORTABLE MIXERS

For over 40 years Hayward Gordon has been supplying fluid mixers to the process industries.

Our portable units incorporate design philosophy from our larger mixers resulting in a compact, rugged series of clamp mount and fixed mount agitators. With sizes ranging from 1/4 to 3 HP, output speeds from 230 to 3500 RPM and a wide variety of mixing impellers to choose from, we can optimize mixer selections for your high flow or high shear requirements.

A variety of shaft sealing systems are available for closed tank applications and various materials and coatings are available for corrosive and/or abrasive service



**CLAMP MOUNT
DIRECT DRIVE**



**CLAMP MOUNT
GEAR DRIVE**

PORTABLE MIXER MODEL NUMBERING

Example: **G X - 15**

Digit Location	Description	Character	Description
First	Drive Type	D	Direct Drive
		G	Gear Drive
Second	Mounting Configuration	C	Clamp Mount
		X	Open Tank
		S	Stuffing Box
		M	Mechanical Seal
Third & Forth	Horsepower Code	14	0.25 HP
		13	0.33 HP
		12	0.5 HP
		34	0.75 HP
		11	1.0 HP
		15	1.5 HP
		2	2.0 HP
	3	3.0 HP	

-Air motor drives are indicated by a letter "A" after the Mounting Configuration Digit

-Side Entry Mixers are identified by a letter "S" before the Drive Type Digit

**FIXED MOUNT
DIRECT DRIVE**



**FIXED MOUNT
GEAR DRIVE**



**ALTERNATIVE
MOUNTING
CONFIGURATION**

Cup Mount for
permanent installation
while preserving angular
adjustment



Fixed Mount
foot print

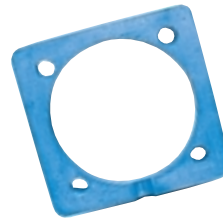

12" square baseplate



12" square 10° angle riser



CLAMP MOUNT

Our easy-to-handle clamp mount series of portable mixers are available in 1/3 to 3 HP sizes as both direct coupled or with a 5:1 gear reduction. The direct drive models (DC series) are available with impeller speeds of 1150, 1750 or 3500 RPM, and are primarily used for either blending of smaller volumes or when high shear mixing is required. Our gear driven models (GC series) are available with output speeds of 230 or 350 RPM. These units are normally used to mix larger volumes of low viscosity material or to blend higher viscosity fluids in smaller batches – use the selection chart on the back cover as a guide to portable mixer selections.

Both the gear and direct drive units are available as either clamp mounted, which fixes the mixer to the side of the tank, or with a cup mount which permanently bolts to the rim of the tank while preserving angular adjustment.

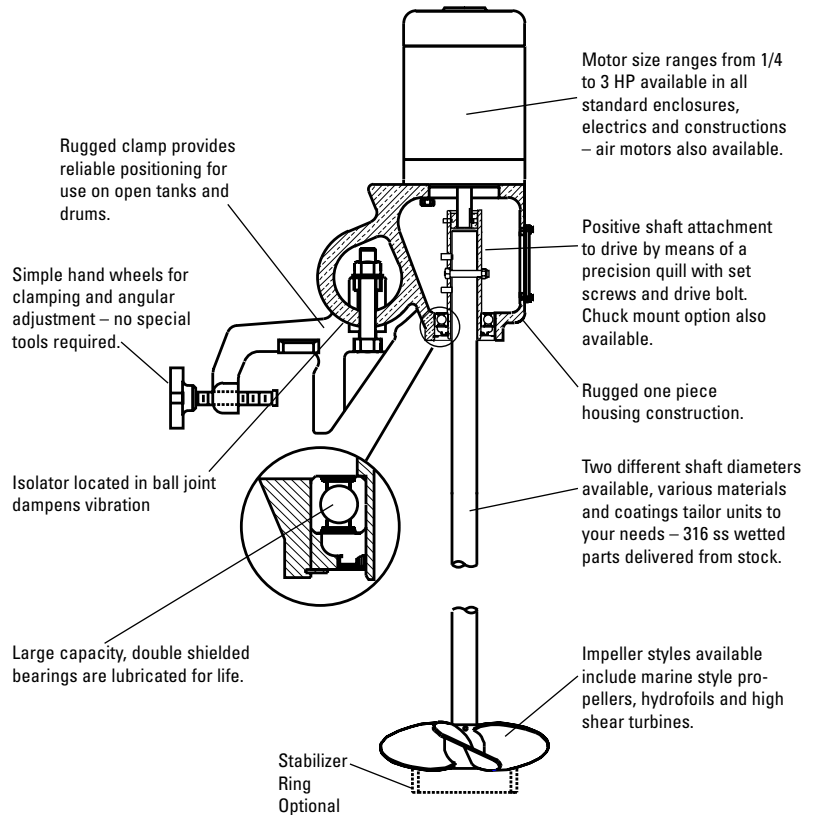

FIXED MOUNT

Our fixed mount series of portable mixers are also available as direct drive or gear driven models, as detailed above, but are permanently bolted to the tank.

Mounting configurations include a baseplate mounted drive support by structural steel spanning the tank, a 10° angle riser also supported by beams across the tank and mixers mounted on ANSI flanges. Numerous shaft sealing systems are available for flange mounted units including; lip seals, V-rings, packing, single dry running mechanical seal and wet or dry running double mechanical seal.

Three sizes of shafting is available, 0.75", 1.25", and 1.5" diameter, to ensure the mixers meet all the application requirements.

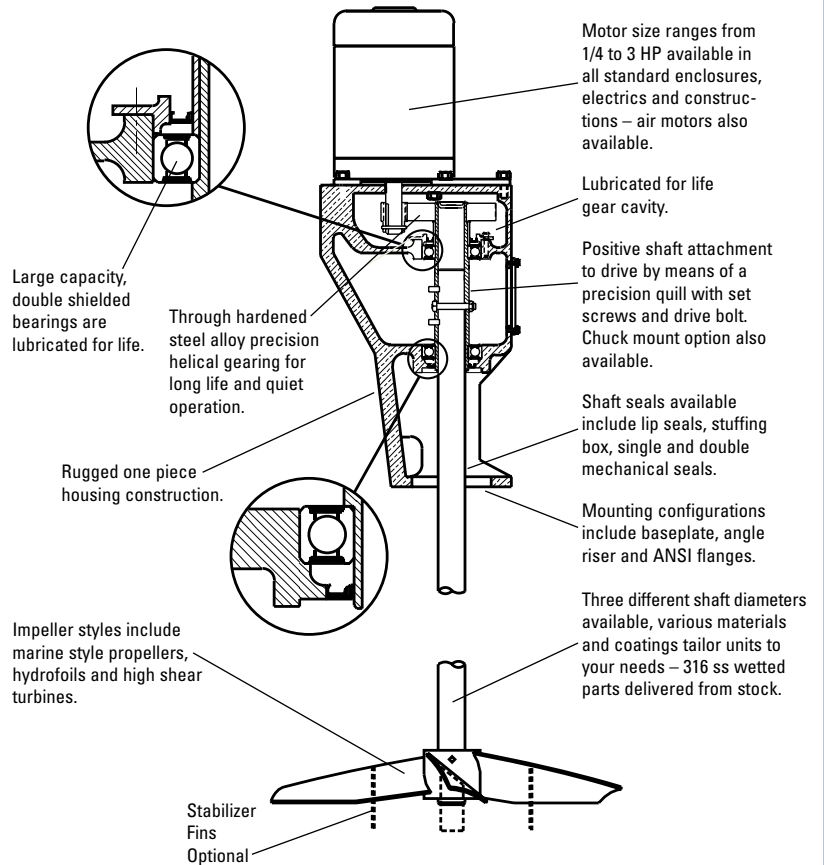



M I X E R P O S I T I O N I N G

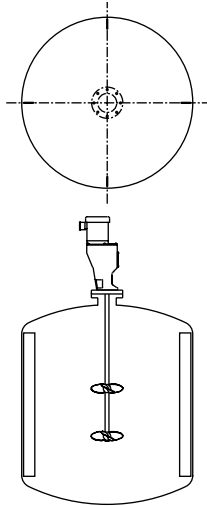

When the mixer is mounted vertically on the vessel centerlines, tank baffles are required. Normal baffle configuration is 4 @ 90° with the baffle width 1/12 the tank diameter for waterlike viscosities.

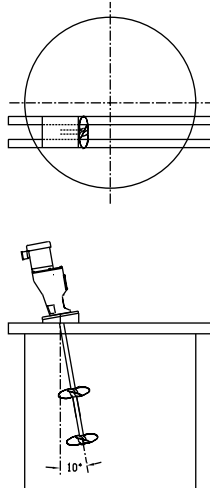

In tanks with no baffles, mixers must be offset and angle mounted as shown above to minimize swirl and vortexing ensuring a good top to bottom mixing motion.

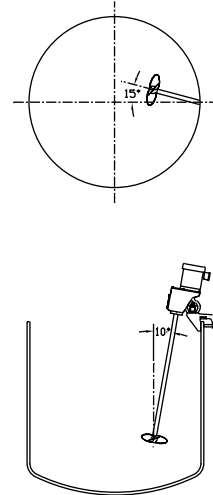

Clamp mounted units are usually configured as shown above - shaft angled 10-15° from vertical and 15° from the tanks plan view, horizontal centerline.

S E A L I N G

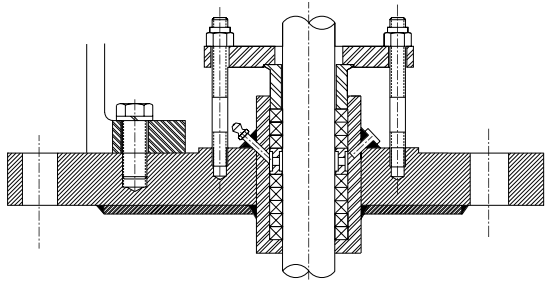

STUFFING BOX-HIGH OR LOW PRESSURE 0-150 P.S.I.
HIGH PRESSURE SHOWN

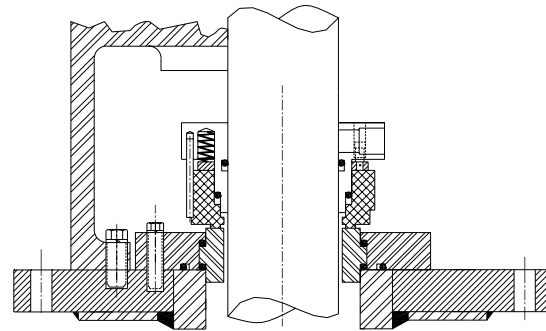

SINGLE DRY RUNNING MECHANICAL SEAL

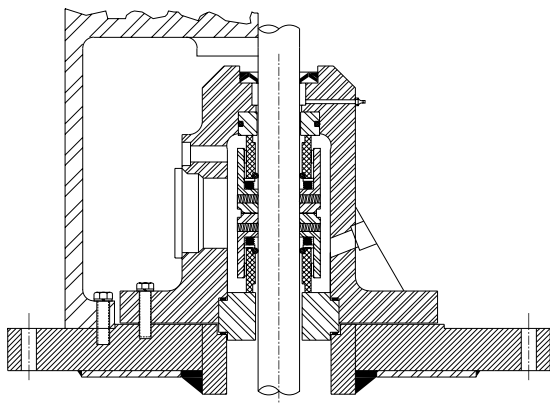

WET OR DRY RUNNING DOUBLE MECHANICAL SEAL

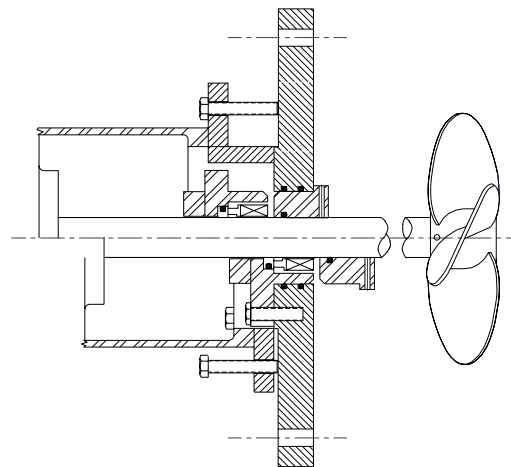

SIDE ENTRY CONFIGURATION WITH SINGLE MECHANICAL SEAL & RE-PACK DEVICE



H A Y W A R D G O R D O N L T D .

P O R T A B L E M I X E R S E L E C T I O N C H A R T

VISCOSITY (CENTIPOISE)	TANK GALLONAGE										MIXING ACTION
	25	50	100	200	500	1000	2000	3000	5000		
(1) WATER (1) KEROSENE (32) SOUR CREAM	1.0	DC-14 Single 3.5" 2 min. B.T.	DC-14 Single 3.5" 3 min. B.T.	DC-14 Single 3.5" 6 min. B.T.	DC-14 Single 3.5" 12 min. B.T.	DC-13 Dual 3.25" 20 min. B.T.	GC-14 Single 9.5" 16 min. B.T.	GC-14 Single 9.5" 30 min. B.T.	GC-13 Dual 9.0" 33 min. B.T.	GC-34 Dual 10.5" 35 min. B.T.	Mild
					DC-12 Single 4.0" 8 min. B.T.	GC-13 Dual 9.0" 6 min. B.T.	GC-12 Single 10.5" 12 min. B.T.	GC-12 Single 10.5" 24 min. B.T.	GC-34 Dual 10.5" 21 min. B.T.	GC-15 Dual 12.5" 21 min. B.T.	Vigorous
(100) SAE 10 OIL	100	DC-14 Single 3.5" 2 min. B.T.	DC-14 Single 3.5" 4 min. B.T.	DC-14 Single 4.0" 5 min. B.T.	DC-13 Dual 3.25" 8 min. B.T.	GC-14 Single 9.5" 11 min. B.T.	GC-14 Single 9.5" 21 min. B.T.	GC-13 Single 10.0" 36 min. B.T.	GC-34 Dual 10.5" 28 min. B.T.	GC-11 Dual 11.5" 36 min. B.T.	Mild
					DC-12 Dual 9.0" 3 min. B.T.	GC-13 Single 10.5" 8 min. B.T.	GC-12 Single 10.5" 16 min. B.T.	GC-12 Single 11.5" 24 min. B.T.	GC-15 Dual 12.5" 17 min. B.T.	GC-2 Dual 13.0" 25 min. B.T.	Vigorous
(240) LARD MAYONNAISE	250	DC-14 Single 3.25" 4 min. B.T.	DC-14 Single 3.5" 7 min. B.T.	DC-13 Dual 3.25" 10 min. B.T.	GC-14 Single 9.5" 7 min. B.T.	GC-13 Single 9.5" 18 min. B.T.	GC-13 Single 10.0" 31 min. B.T.	GC-34 Single 11.5" 42 min. B.T.	GC-11 Dual 11.5" 38 min. B.T.	GC-15 Dual 12.5" 49 min. B.T.	Mild
					DC-12 Single 4.0" 5 min. B.T.	GC-13 Dual 9.0" 3 min. B.T.	GC-12 Single 10.5" 5 min. B.T.	GC-11 Single 10.5" 14 min. B.T.	GC-15 Single 11.5" 21 min. B.T.	GC-2 Dual 13.0" 26 min. B.T.	GC-3 Dual 14.25" 34 min. B.T.
(900) YOGURT CASTOR OIL GLYCERIN	1000	DC-13 Dual 2.75" 10 min. B.T.	GC-14 Dual 6.0" 10 min. B.T.	GC-14 Dual 6.0" 19 min. B.T.	GC-12 Single 10.0" 14 min. B.T.	GC-34 Single 10.5" 35 min. B.T.	GC-11 Single 11.5" 48 min. B.T.	GC-15 Dual 11.5" 57 min. B.T.	GC-2 Dual 12.5" 67 min. B.T.	GC-3 Dual 13.0" 99 min. B.T.	Mild
					GC-11 Single 11.5" 10 min. B.T.	GC-15 Single 12.5" 19 min. B.T.	GC-2 Single 12.5" 38 min. B.T.	GC-3 Dual 13.0" 40 min. B.T.			Vigorous
(3000) BLACKSTRAP MOLASSES	2500	GC-14 Dual 5.5" 11 min. B.T.	GC-14 Dual 5.5" 22 min. B.T.	GC-12 Dual 7.0" 24 min. B.T.	GC-34 Dual 9.0" 22 min. B.T.	GC-11 Dual 10.0" 39 min. B.T.	GC-15 Dual 10.5" 70 min. B.T.	GC-2 Dual 11.5" 107 min. B.T.	GC-3 Dual 13.0" 112 min. B.T.		Mild
					GC-15 Dual 10.5" 8 min. B.T.	GC-2 Dual 11.5" 14 min. B.T.	GC-3 Dual 13.0" 27 min. B.T.				Vigorous
HONEY (5000) BLACKSTRAP MOLASSES	5000	GC-14 Dual 5.5" 17 min. B.T.	GC-12 Dual 7.0" 18 min. B.T.	GC-34 Dual 7.75" 27 min. B.T.	GC-11 Dual 9.0" 34 min. B.T.	GC-15 Dual 10.0" 60 min. B.T.	GC-2 Dual 11.5" 82 min. B.T.	GC-3 Dual 12.5" 128 min. B.T.			Mild
					GC-2 Dual 9.0" 9 min. B.T.	GC-3 Dual 11.5" 17 min. B.T.	GC-3 Dual 12.5" 32 min. B.T.				Vigorous
CORN SYRUP APPLESAUCE (11200) MUSTARD	10,000	GC-13 Dual 6.0" 20 min. B.T.	GC-12 Dual 6.5" 33 min. B.T.	GC-34 Dual 7.0" 53 min. B.T.	GC-15 Dual 9.5" 42 min. B.T.	GC-2 Dual 10.0" 89 min. B.T.	GC-3 Dual 11.5" 120 min. B.T.	CONSULT FACTORY FOR APPLICATIONS IN THIS AREA			Mild
					GC-3 Dual 9.5" 11 min. B.T.	GC-3 Dual 11.5" 13 min. B.T.	GC-3 Dual 11.5" 21 min. B.T.				GC-3 Dual 11.5" 25 min. B.T.
	15,000	GC-12 Dual 6.0" 24 min. B.T.	GC-34 Dual 7.0" 32 min. B.T.	GC-11 Dual 7.75" 46 min. B.T.	GC-15 Dual 9.0" 58 min. B.T.	GC-3 Dual 11.5" 72 min. B.T.					Mild
					GC-2 Dual 9.0" 12 min. B.T.	GC-3 Dual 11.5" 15 min. B.T.	GC-3 Dual 11.5" 21 min. B.T.				GC-3 Dual 11.5" 29 min. B.T.

Propeller Spacing of 2 (two) propeller diameters is recommended for GC units.

Propeller Spacing of 4 (four) propeller diameters is recommended for DC units.

Blend Times (B.T.) shown are approximate, and are based on blending a pure fluid as opposed to two components with different viscosities.

WORLD WIDE INSTALLATIONS

INCLUDING:

United States, Canada, Mexico, Nicaragua, Chile, Guyana, Venezuela, Peru, Argentina, China, United Kingdom, Russia, Italy, Jordan, Yugoslavia, Nigeria, Indonesia, Taiwan, South Korea, Tunisia, Papua New Guinea and Australia.

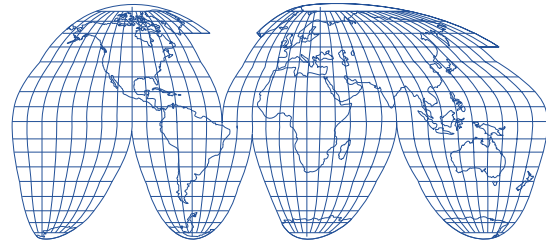

CANADA

6660 Campobello Road
Mississauga, Ontario L5N 2L9
(905) 567-6116 Fax (905) 567-1706

U.S.A.

1051 Clinton Street
Buffalo, New York 14206
(716) 856-4636 Fax (905) 567-1706

Western U.S.A./Western Canada

(604) 986-8764 Fax (604) 986-8794