



The Sala-series
of Vertical and Horizontal ST Pumps
Recessed and Channel Impeller



The Sala-series of ST Pumps

The ST-Pump range consists of tough, general purpose Slurry Pumps particularly known for their Induced Flow impellers. The hydraulic design provides a very gentle handling of the slurry. The proven low attrition of pumped particles has made it the Industrial Standard for Carbon Transfer in Gold Leaching processes. The "Clogless" performance of the Induced Flow impellers also makes this product range ideal for all applications where large or long, stringy solids will be handled.

Vertical Torque Flow Pumps Type STGVA

Vertical wet pit design for pulpy solids and corrosives. With single suction and no shaft sealing the STGVA pump offers outstanding design features.

Cantilever design

The heavy duty pump shaft moves freely under the bearing housing. There are no journal bearings below the liquid level to maintain. The pump has no stuffing box and thus does not require sealing water.

Metallurgy

Hydraulic parts are available from stock in cast iron and stainless steel and high chrome. Some sizes are also available with rubber lined or polyurethane wear parts. The pump frame assemblies below the base plate are available in carbon steel and stainless steel. Other materials are available upon request.

Vortex impeller available

This recessed impeller is located out of the flow pattern. The pumping effect is performed by the vortex that the impeller generates in the slurry. The passage through the vortex pump is fully open, therefore it is especially suited for pumping fibres and similar material.

Impeller adjustment

Easily adjustable shaft allows setting of pump clearances for maximum performance.

V-belt drive

This permits simple cost-effective adjustment of pump flow rate.

Designed for severe pumping

'STGVA' pumps are designed for severe pumping problems of corrosion, abrasion and temperature extremes in the chemical, minerals processing, pulp and paper, brewing, food and other industries.

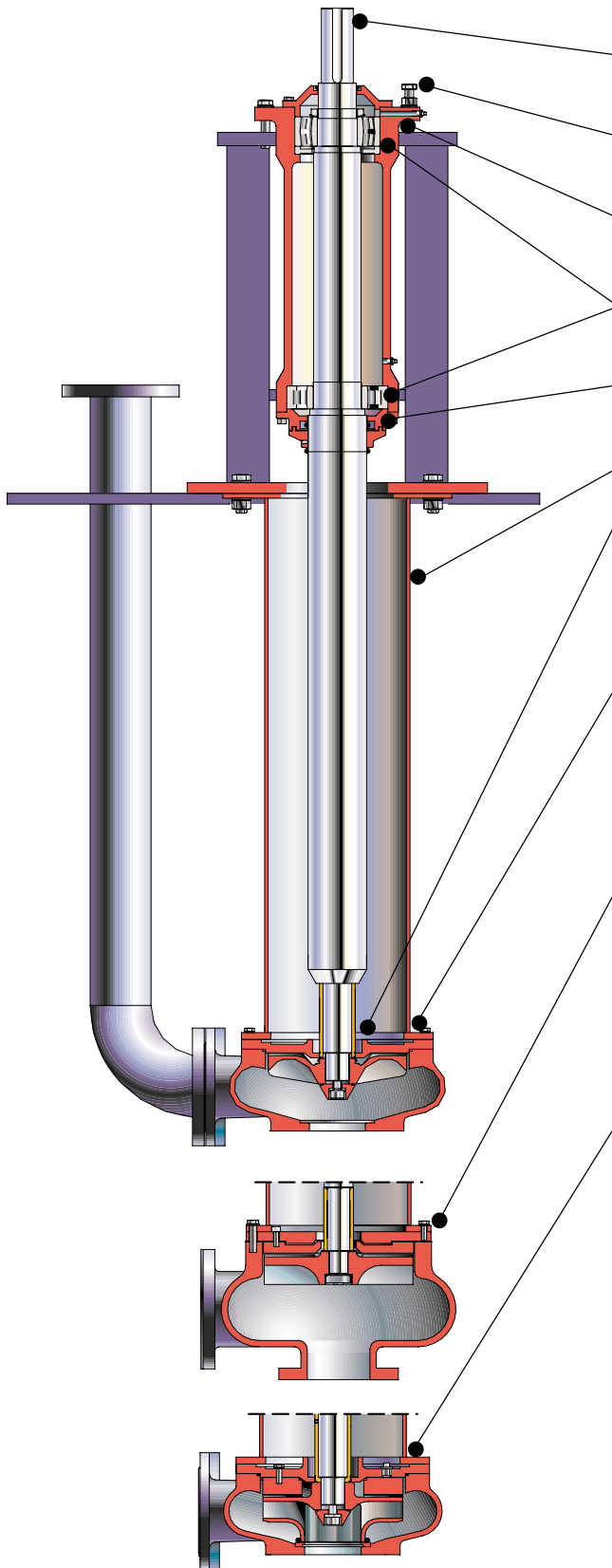

STGVA Vertical Pumps

Heavy Duty, large cantilevered shaft reduces deflection and provides stable mechanical operation.

Simple impeller clearance adjustment from the top of the pump.

Cast Iron bearing housing is piloted in the upper frame to assure perfect alignment.

Oversized grease lubricated roller bearings are designed to provide up to 60,000 hours of trouble free operation.

Grease-purged labyrinth and double V-ring seals effectively eliminate lower bearing contamination.

Rigid lower frame minimizes pedestal deflection.

No submerged bearing or stuffing box provides virtually maintenance-free operation.

Wet-end available in three different impeller configurations. Impellers are keyed onto shaft.

Recessed impeller – large clearance between casing and impeller – well suited for pumping fibrous slurries (paper stock, wood chips, municipal sludge, etc.), aerated or frothy liquids (recessed impeller will not air lock) and any application where the pump is required to pass the occasional large sizes.

Fully-recessed impeller in casing providing full flow through capability and provides “gentle” handling of solids in suspension to prevent the degradation of friable solids (e.g. – carbon transfer in carbon-in-pulp gold recovery process). Also well-suited for handling slurries containing high concentrations of stringy, fibrous solids. Available in discharge sizes of 2”, 3” and 4”.

Channel impeller – fully closed with large passages suitable for pumping liquids and slightly abrasive slurries and sludges. High efficiency due to closed impeller design. Available in discharge sizes of 3”, 4”, 5”, 6”, 8”, 10” and 14”.

Materials of construction – all pumps are available with cast iron, stainless steel. Some sizes are also available High Chrome, CD4MCU and Elastomer lined wear parts.

Drive – pumps can be supplied with V-belt drive or direct drive configuration.

Optional suction pipe – allows additional extension of overall length by 1.8 m.

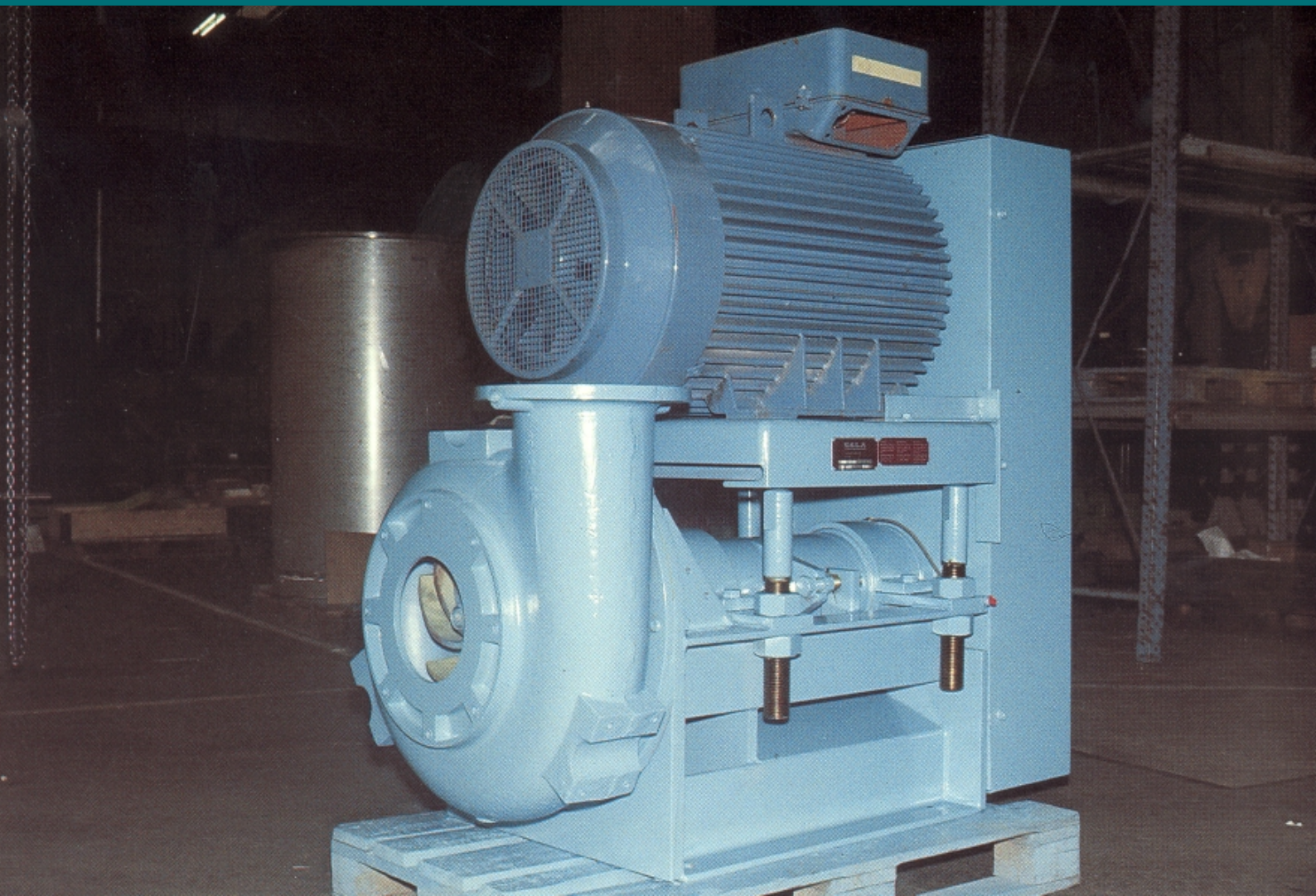

Horizontal Torque Flow Pumps Type STHM

The STHM pumps are also available with alternative impeller designs which allow optimum adaption to different media - from heavy suspensions to clean liquids.

Vortex or channel impeller

Vortex impeller for heavy suspension and liquid/gas mixture. Channel impeller for light suspensions and clean liquids.

V-belt drive

This permits alteration of the pump's performance without opening the pump.

Bearing assembly

Cartridge type with grease lubricated roller bearings designed for more than 60 000 operating hours.

Shaft seal

Standard stuffing box with seal water. Optional mechanical seals.

Pumping parts

Standard pumping parts in cast iron, stainless steel, high chrome and some sizes in Polyurethane or rubber lined. Other materials are available upon request.

Motor bed plate

Overhead motor bed plate gives compact installation with extra motor protection and simple belt tensioning.

Vortex impeller

The vortex impeller is recessed in the back of the pump casing, giving a free passage through the casing. The pump can normally pump anything that can pass through the connecting pipes.

STHM Horizontal Pumps

1. Fabricated steel base is fully machined to provide perfect alignment and concentricity.
2. Large diameter oversized shaft minimizes deflection and provides smooth running, stable operation.
3. Simple impeller clearance adjustment from drive side of pump.
4. Heavy duty grease lubricated roller bearings enclosed in a cartridge type bearing housing.
5. Overhead motor plate for V-belt drive operation minimizes space requirements (side by side baseplates or common baseplate for direct drive also available).
6. Grease purge labyrinth and double V-ring seals prevent the ingress of dirt and liquid into the bearing house.
7. Conventional packed stuffing box is standard. Mechanical seal available as an option.
8. Impeller configurations identical to STGVA vertical pumps – i.e. recessed, fully recessed or channel impeller. Casing and impeller are interchangeable between identical sizes of vertical and horizontal pumps.

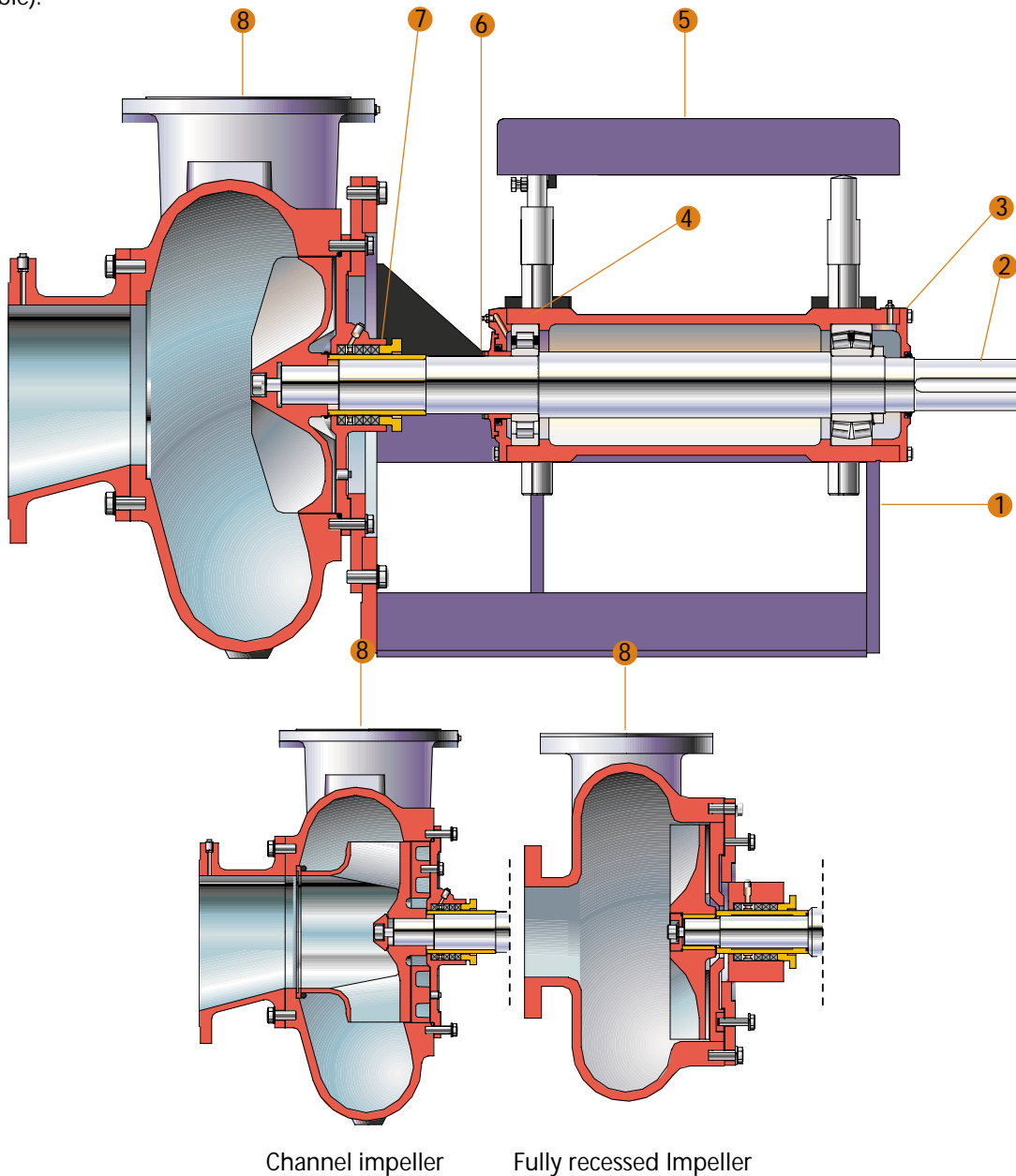

Channel impeller

Fully recessed Impeller

Selection of pump size

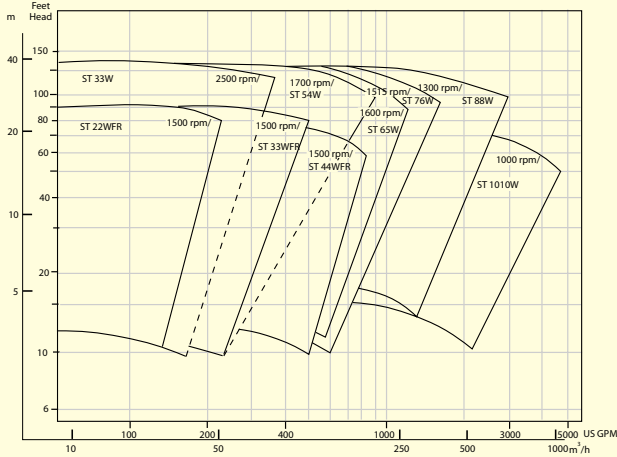

Vortex impeller*

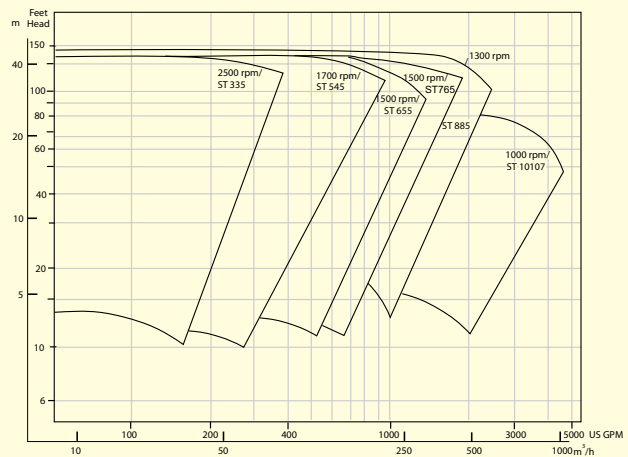

Channel impeller**

Pump Dimensions

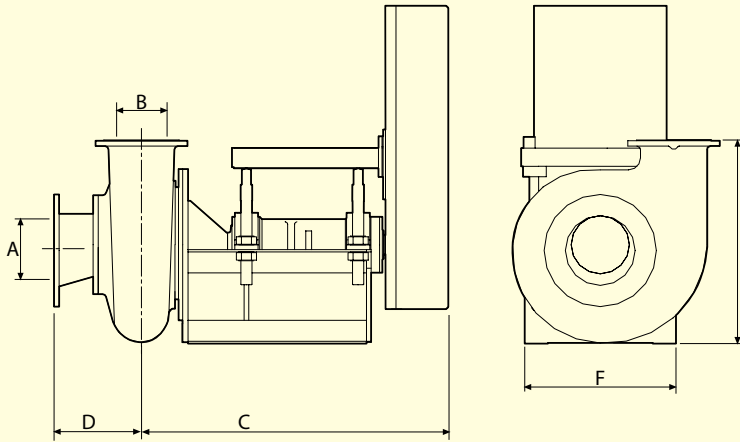

Pump type STHM, size	Measures in Inch (mm)						Max. motor			Weight lbs kg
	A	B	C	D	E	F	nema hp	(IEC)	(kW)	
22WFR	2 (51)	2 (51)	31.5 (802)	4 (100)	18.3 (465)	15.4 (390)	286T 30	(180 L)	(22)	330 (150)
33WFR	3 (76)	3 (76)	31.5 (802)	4.5 (116)	19.3 (490)	15.4 (390)	286T 30	(180 L)	(22)	355 (160)
44WFR	4 (102)	4 (102)	32 (813)	5.2 (133)	19.9 (505)	15.4 (390)	286T 30	(180 L)	(22)	385 (175)
33	3 (76)	3 (76)	30.2 (768)	7.5 (190)	18.5 (470)	15.4 (390)	286T 30	(180 L)	(22)	330 (150)
44	4 (102)	4 (102)	31.5 (803)	8.3 (210)	20 (510)	17 (430)	326T 50	(225 S)	(37)	650 (295)
54	6 (152)	4 (102)	40.7 (1035)	8.3 (210)	20.9 (530)	17 (430)	326T 50	(225 S)	(37)	650 (295)
65	6 (152)	5 (127)	45.5 (1159)	8.7 (222)	25.5 (650)	19.7 (500)	365T 75	(250 S)	(55)	840 (380)
76	8 (203)	6 (152)	46 (1169)	9.5 (241)	26.4 (670)	19.7 (500)	365T 75	(250 S)	(55)	915 (415)
88	10 (254)	8 (203)	49 (1248)	11 (279)	31.8 (810)	25.6 (650)	444T 125	(280 S)	(90)	1050 (475)
1010	12 (305)	10 (254)	50.8 (1292)	14.8 (375)	34.5 (880)	25.6 (650)	444T 125	(280 S)	(90)	1155 (525)
1414	14 (356)	14 (356)	62.5 (1590)	20 (511)	46.3 (1175)	29.5 (749)	447T 125	(280 S)	(90)	1600 (725)

*Pumps with vortex impeller are identified with W, e.g. STHM 76 W.

**Pumps with channel impeller are identified with a digit, e.g. STHM 76 5. The digit specifies number of vanes in the impeller.

The information contained herein is general and is not intended for specific installation or application purposes. Metso Minerals reserves the right to make changes in specifications shown herein at any time without notice or obligation.

Slurry Pumps

Our Range:

Horizontal. Rubber and Metal
XR/XM, Extra Heavy Duty Pumps
HR/HM, Heavy Duty Pumps
MR/MM, Mining Duty Pumps
Dredge Pumps

Vertical. Rubber and Metal
VF, Froth Pumps
VS, Sump Pumps
VT, Tank Pumps

Metso Minerals
Avda. Vitacura 4380, 5^o Floor,
Vitacura, Santiago
Chile
Phone: +56 2 370 2000
Fax: +56 2 370 2039

Metso Minerals
SE-733 25 Sala
Sweden
Phone: +46 224 570 00
Fax: +46 224 169 50

Metso Minerals
P.O. Box 340
Colorado Springs, CO 80901
USA
Phone: +1 719 471 3443
Fax: +1 719 471 4469

Metso Minerals
4050 B Sladeview Crescent
Mississauga, Ontario L5L 5Y5
Canada
Phone: +1 905 607 3330
Fax: +1 905 607 3339

Metso Minerals
7, Parker Centre, Mansfield Road
Derby, DE21 4SZ
United Kingdom
Phone: +44 1332 38 00 89
Fax: +44 1332 20 70 81

Metso Minerals
Private Bag X2006
Isando, Johannesburg, 1600
South Africa
Phone: +27 11 397 5090
Fax: +27 11 397 5826

Metso Minerals
18 Lidco Street
Arndell Park, NSW 2148
Locker Bag 10
Blacktown BC, NSW 2148
Australia
Phone: +61 2 8825 1600
Fax: +61 2 8825 1799

www.metsominerals.com
E-mail: minerals.info@metso.com
Pumps information at
www.metsominerals.com/pumps

