



The X Series of Extra Heavy Duty Horizontal Slurry Pumps



The X Series of Extra Heavy Duty Rubber Lined and Hard Metal Slurry Pumps

The SvedalaXR (rubber lined) and XM (hard metal), Extra Heavy Duty Slurry Pump range is designed for the most arduous pumping applications.

The rugged "wet end" is designed with extra thick metal or rubber sections at known points of wear and the high aspect ratio metal or rubber impeller ensures excellent performance with long wear life.

Example of pump designation XR 350

Inlet Size (mm)
Pump Range: XM Metal

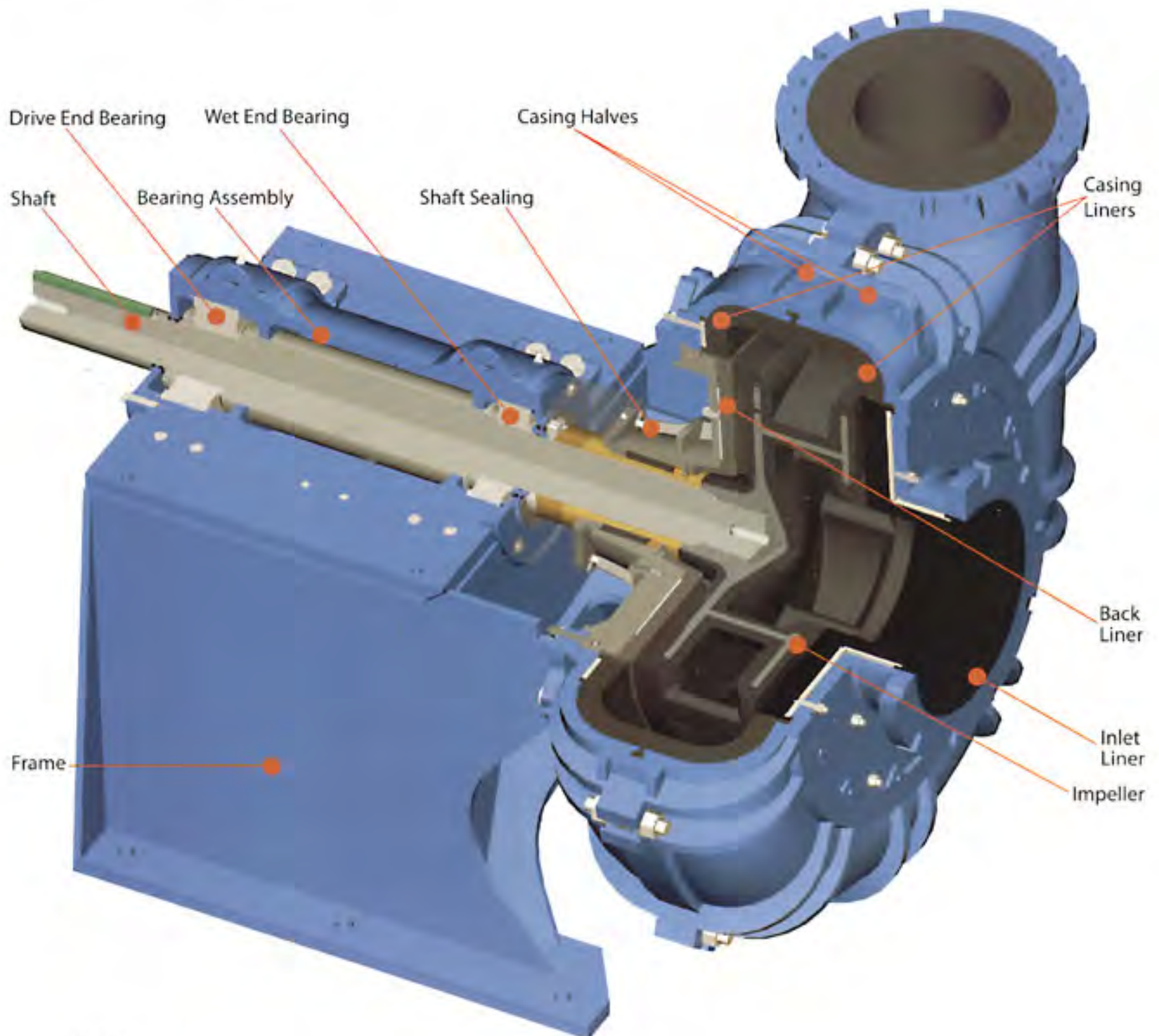

XR 400

Summary of Design Features

- Modular design technology
- Robust construction designed for highly abrasive, maximum duty
- Computer aided designed thick volute casings and heavy duty large diameter impellers, carefully matched, to provide high efficiency, hydraulics for even wear
- Materials used are the very best available, providing both excellent wear properties and corrosion resistance
- Self contained bearing cartridge assembly with oversized shaft and anti-friction bearings
- Various shaft seal options
- Ease of maintenance

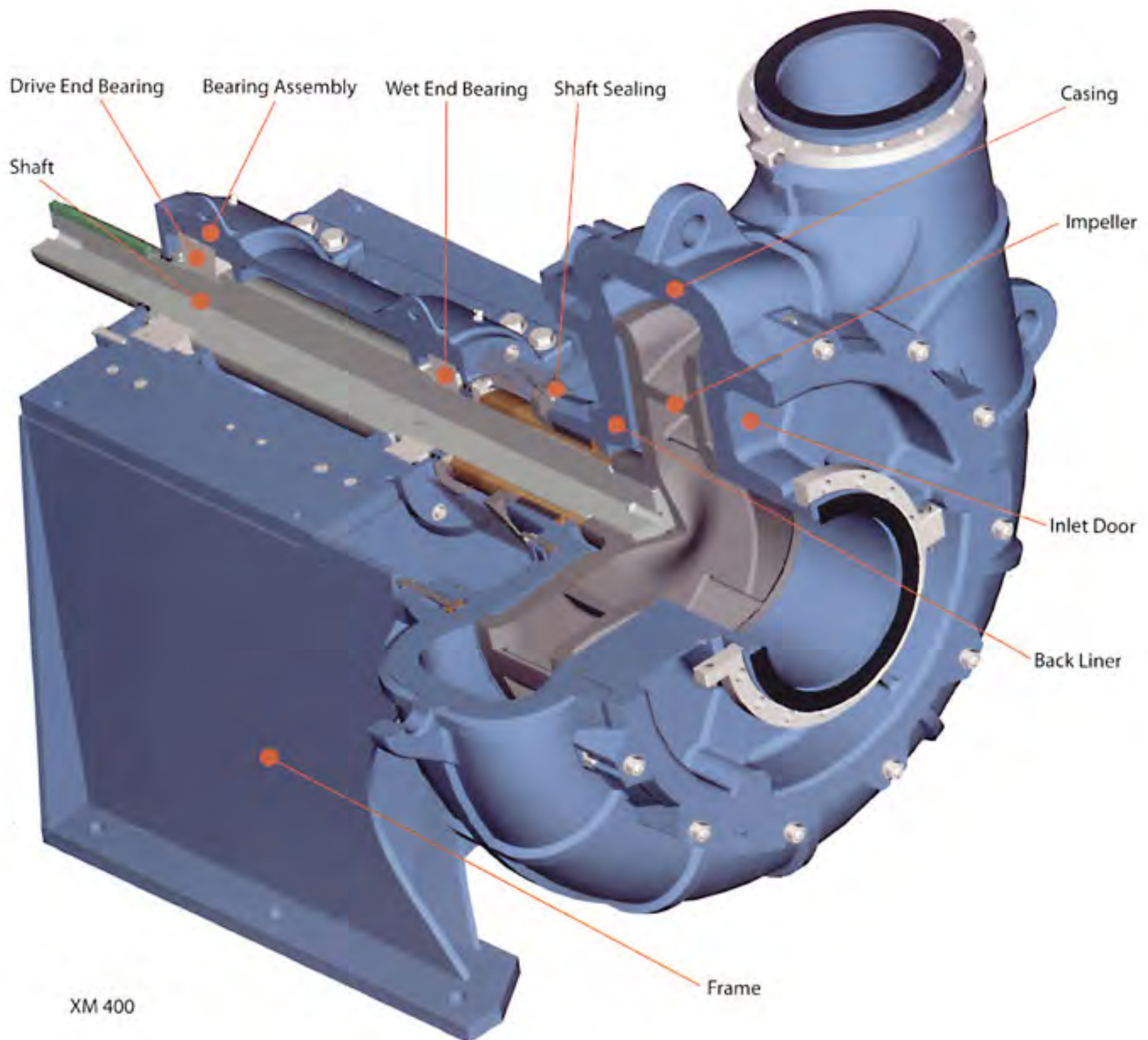

XM 400



metso

Details of Design Features

Modular Design

State of the art computer aided design provides an extremely robust, yet compact, end suction unit. The carefully executed modular design technology allows optimum pump and material selection. These pumps operate at or near their highest efficiency, thereby reducing both the rate of wear and the power consumed.

Maximum interchangeability of spares is also ensured, including material options.

Hydraulics

The compact end suction design, with a volute pump casing, provides smooth, highly efficient, hydraulic flow and minimum radial loading.

The heavy duty solids handling impeller, with a high aspect ratio (Impeller Diameter/Inlet Diameter), combined with carefully matched, high efficiency, hydraulics ensure minimum turbulence, low NPSH required and extended, even wear life.

Hydraulic performance is maintained as the pump wears by axially adjusting the impeller, shaft and bearing assembly.

Bearing Assembly

The oversized high strength alloy steel shaft is carried in grease or oil lubricated anti-friction bearings mounted in a self-contained cartridge assembly. The cartridge itself fits on to a severe duty bearing frame and is easily replaced with a minimum of down-time.

Shaft Sealing

The standard pump has a primary high-performance dry hydrodynamic expeller which effectively seals the gland when the pump is running. A secondary grease-lubricated packed gland seal prevents leakage when the pump is not running.

Flushed gland seals are available which can be supplied as either a "full flow" or "low flow" gland seal.

Various options of mechanical seals are available upon request.

The materials used in the "wet end" are dependent on the application. The options are the very best available, providing excellent wear properties and corrosion resistance. The standard impeller material **MetaChrome**, is a high Chrome iron alloy with a nominal hardness of 600 BHN. The standard rubber liner material is **ElastaWear**, a high-performance natural rubber.

Other material options are available upon request.



XR 400



XM 400

Features and Benefits

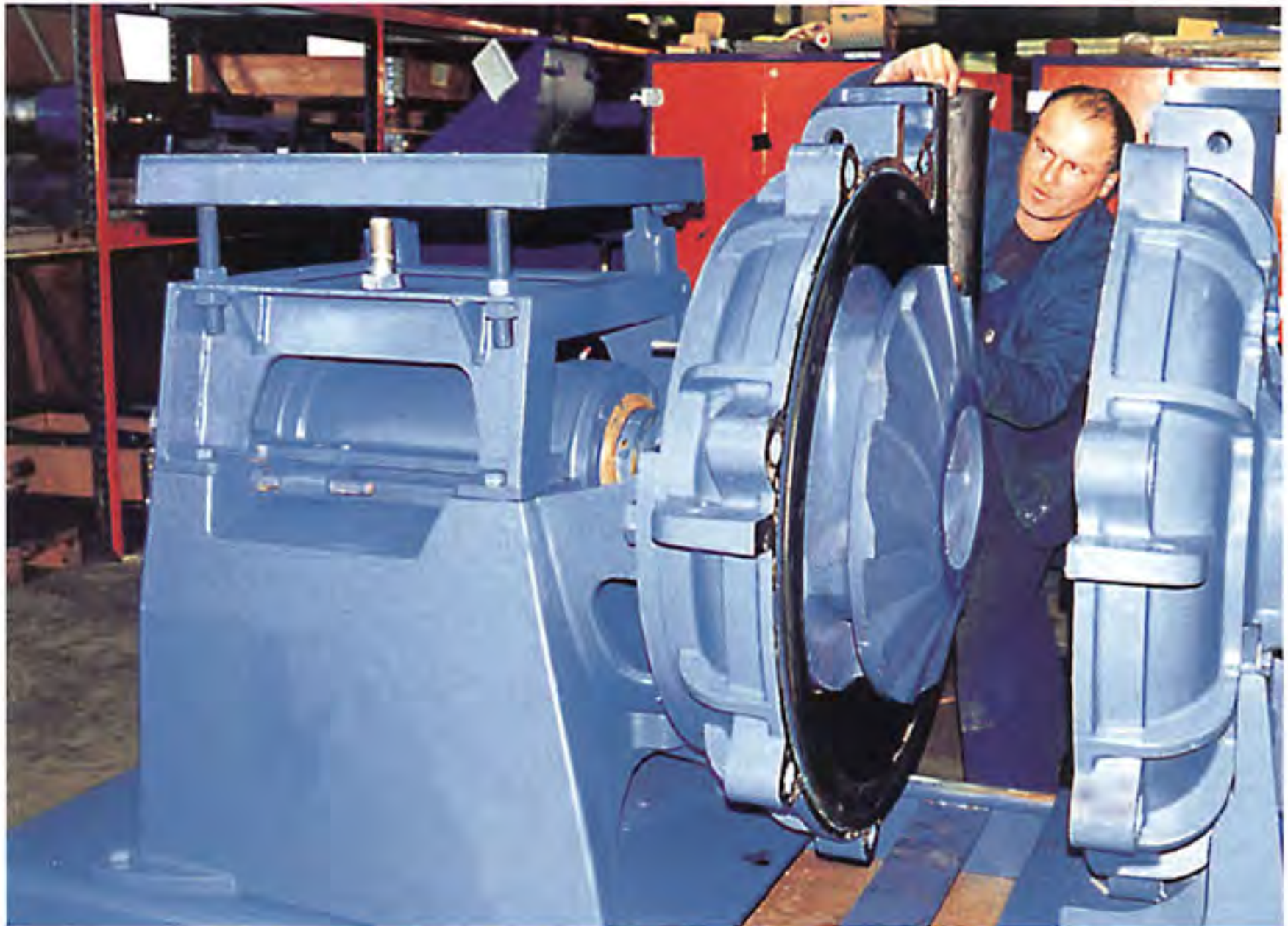

Ease of Maintenance

The unique "crowbar-operated" Slide Base option, combined with the "back pull-out" feature, gives immediate access to the rotating assembly and shaft seal without disturbing the inlet and outlet connections

Motor Size

Motor size and Vee-Belt drive vary with the pump application. Minimum data required for an approximate pump, speed and drive motor selection:

- Slurry flow rate
- Slurry density
- Total discharge head

Typical Installations

- Ball and Rod Mill Discharge / Regrind
- Phosphate Tailings
- Phosphate Matrix
- Abrasive Pulps
- Iron Ore Slurry
- Copper Concentrate Service
- Coal Slurry

- Power Plant Ash Slurries
- Mine Tailings
- Sand

Options

Slide Base

For ease of maintenance

Motor Mountings

Side mounted
Overhead mounted
Reverse overhead mounted
Direct in line mounted

Shaft Seals

Expeller seal
Full/low flow, flushed, packed gland seals
Mechanical seal arrangements
Flanged Connections and Outlet position
To suit customer requirements

Selection of Pump Size

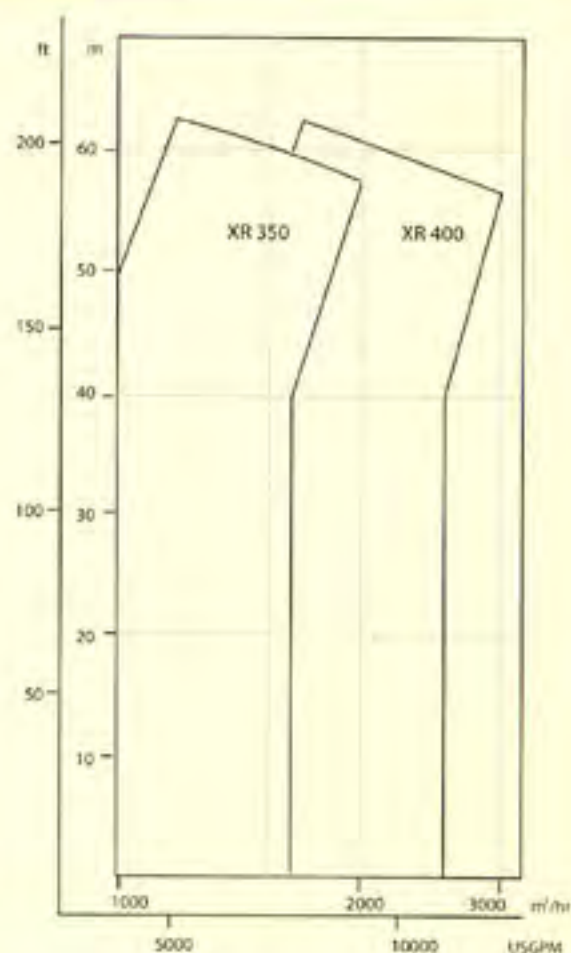
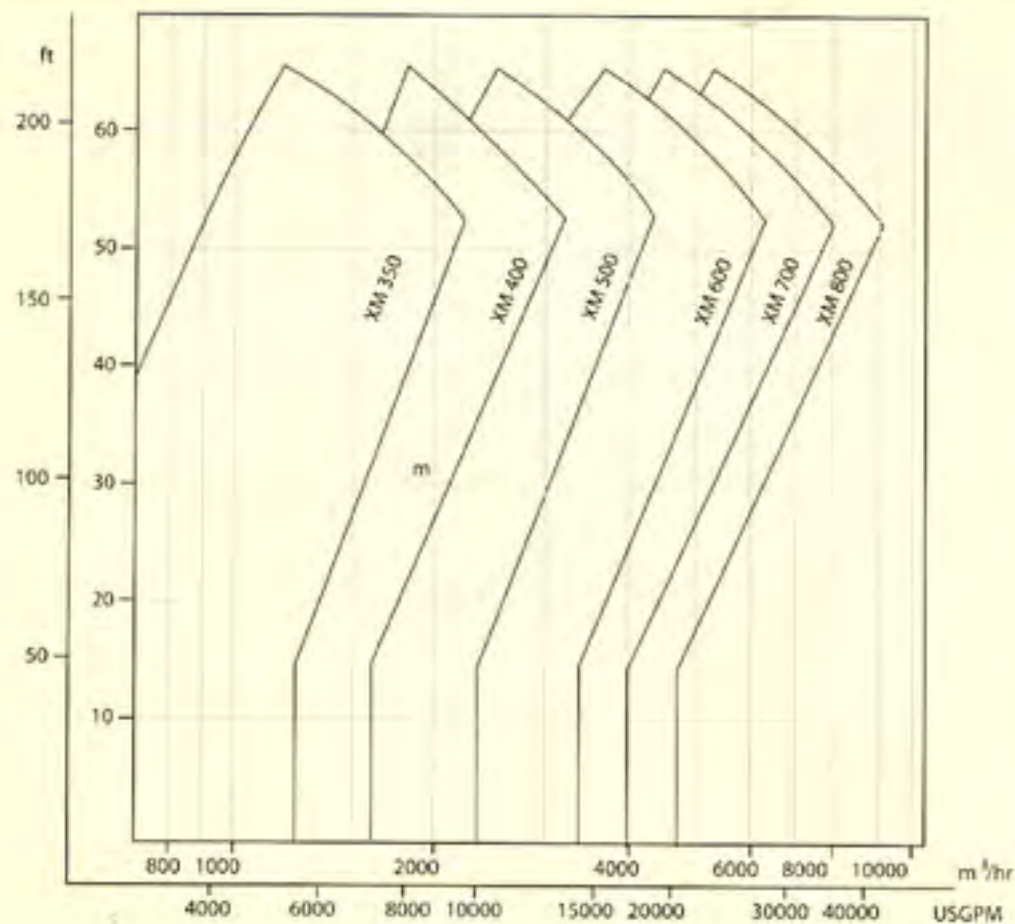

Pump Dimensions

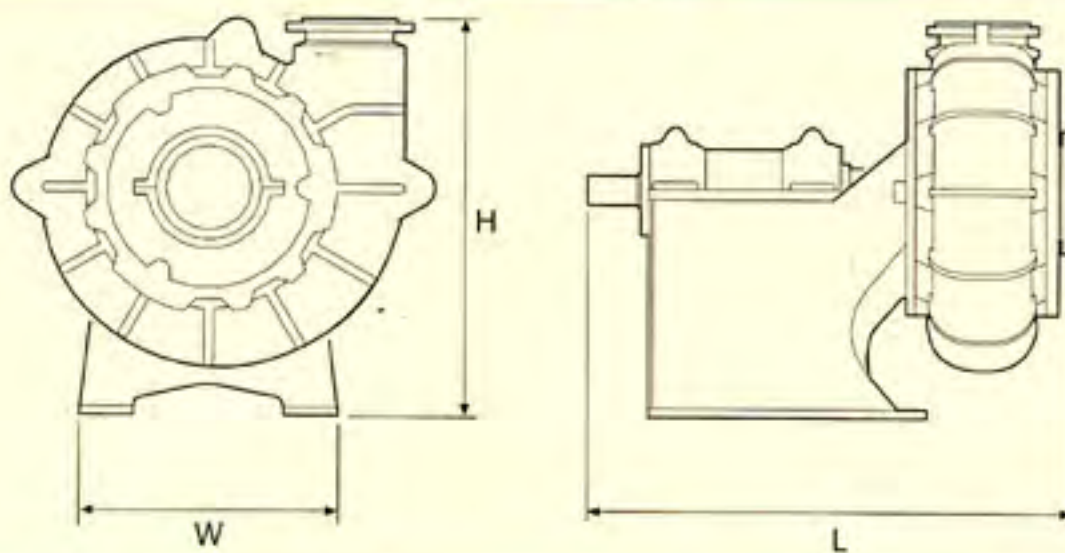

Model	Inlet		Outlet		H		L		W		Weight*	
	mm	inch	mm	inch	mm	inch	mm	inch	mm	inch	kg	lb
XM350	350	14	300	12	1 727	68	1 808	71	1 110	44	5 000	11 023
XM400	400	16	350	14	1 881	74	1 980	78	1 204	47	6 700	14 770
XM500	500	20	450	18	2 150	84	2 145	84	1 380	54	9 820	21 649
XM600	600	24	550	22	2 468	97	2 308	91	1 566	61	14 975	33 014
XM700	700	28	650	26	2 560	100	2 324	91	1 565	61	19 940	43 940
XR350	350	14	300	12	1 727	68	1 808	71	1 110	44	4 221	9 305
XR400	400	16	350	14	1 881	74	1 980	78	1 204	47	5 363	11 823

* Bare shaft weight