

# Mixer Offering



Portable



Transition Top Entry  
- Between Potable /  
Larger Turbine Style  
- HRF



Small Top Entry with  
Gear Box - ST



Medium Top Entry  
with Gear Box - MB



Large Top Entry  
with Gear Box - LH



Mag Drive Top Entry



Side Entry



Dynamic In-line Mixers



Specials  
Bottom Entry



Specialty  
Belt Drive

From .25 hp to 400 HP

# Mixers Standard Products

## Small Top Entry - ST Series

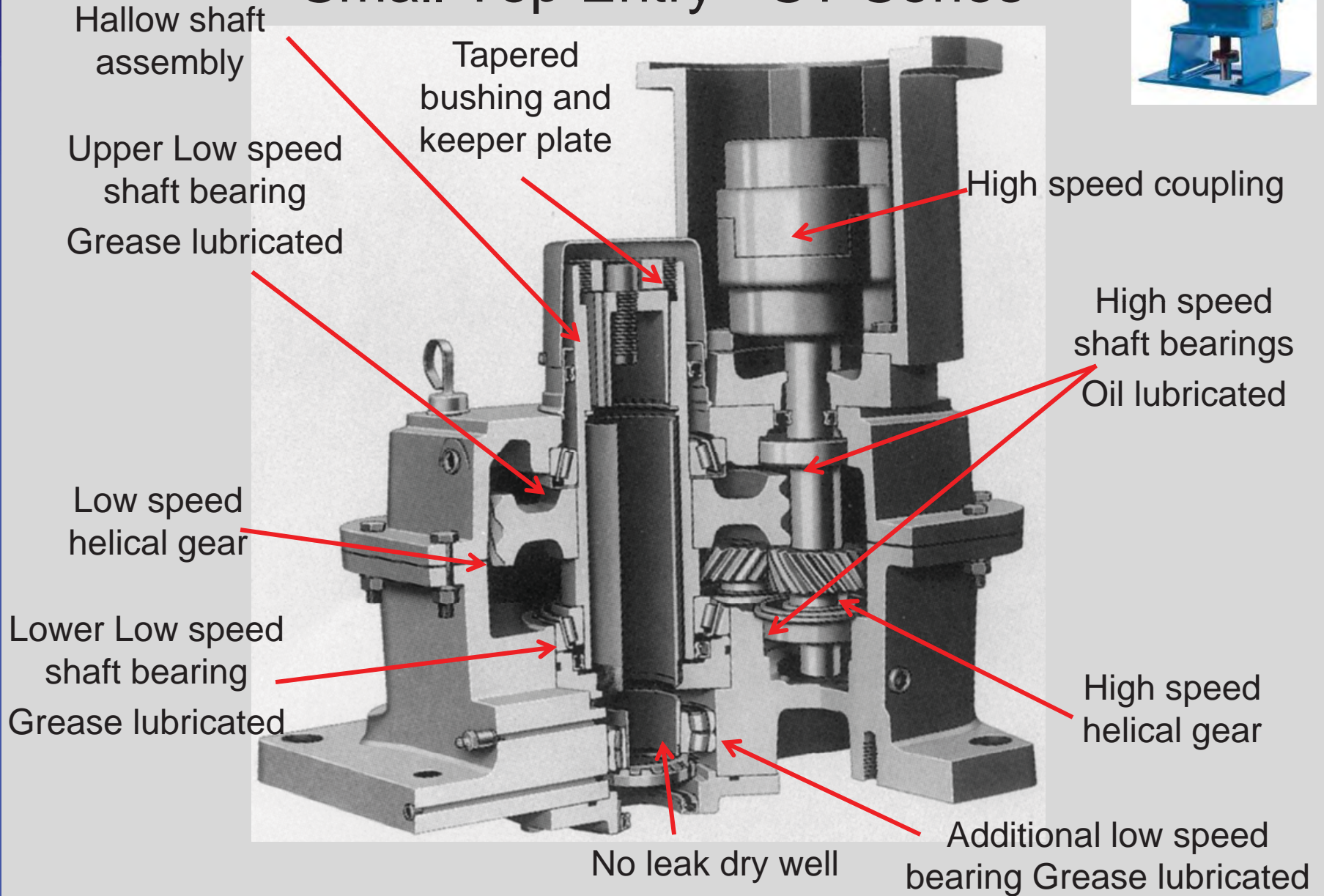

# Mixers Standard Products

## Mid Size Top Entry - MB Series

- Horsepower range 7.5 to 150
- Typical Volume range 20,000 to 200,000 US gallon tanks
- MB Series right angle drives come in seven different sizes covering moderate size mixing applications
- 21 Standard output speeds are available between 350 and 6 rpm
- Standard as dry well
- Optional: Open tank, stuffing box, double or single mechanical seals wet or dry running

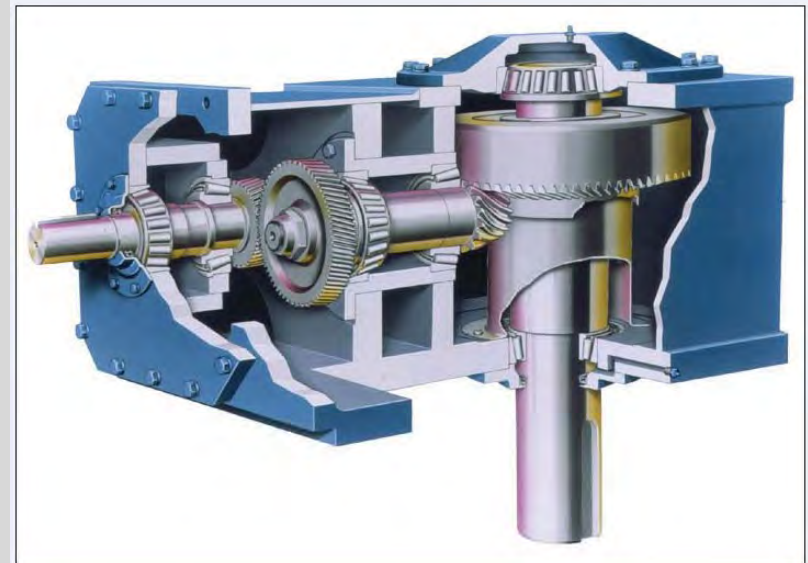

# Gearbox Overview

## Mid Size Top Entry - MB Series

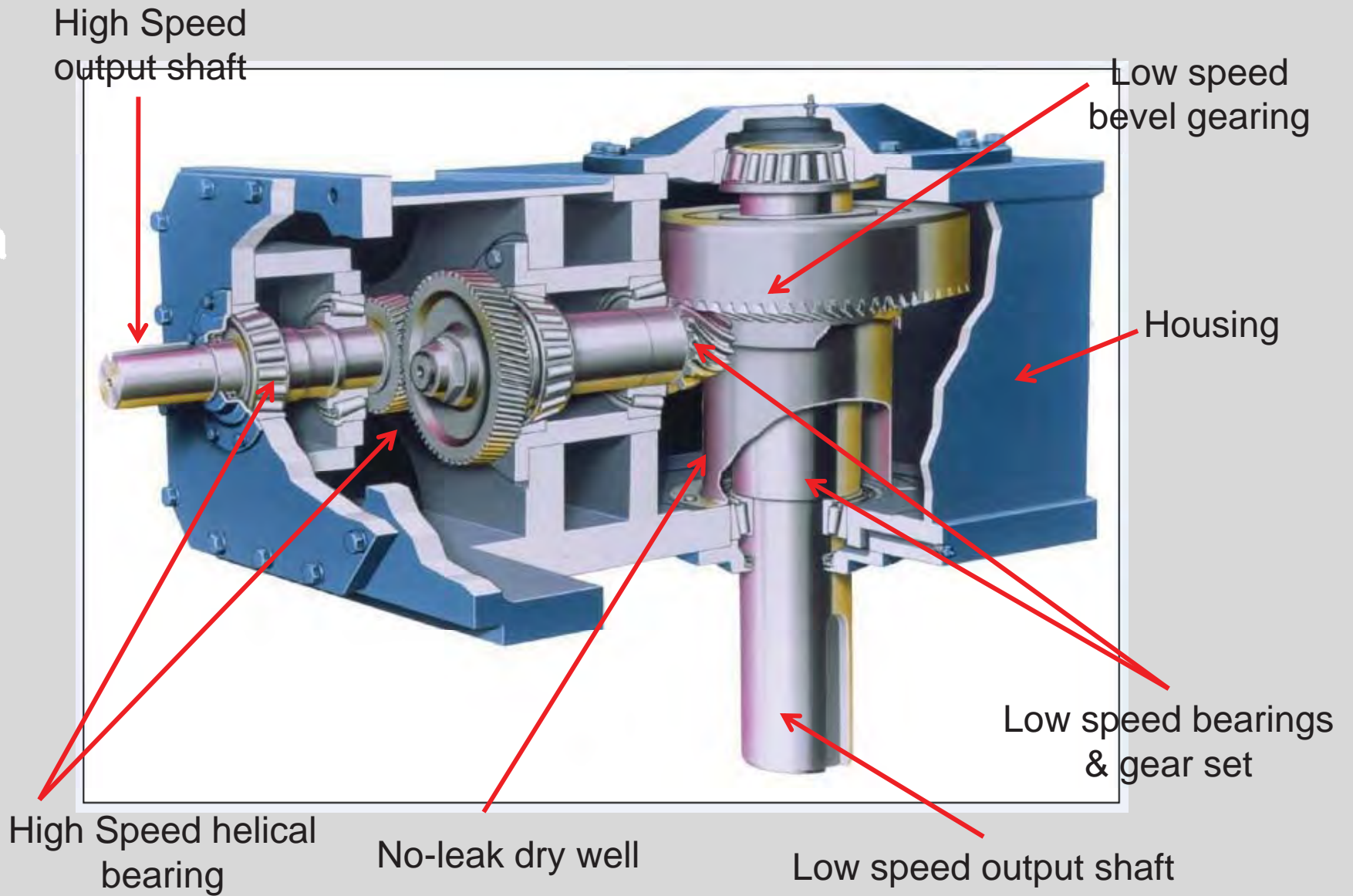

# Gearbox Maintenance LH Series

## Large Top Entry - LH Series

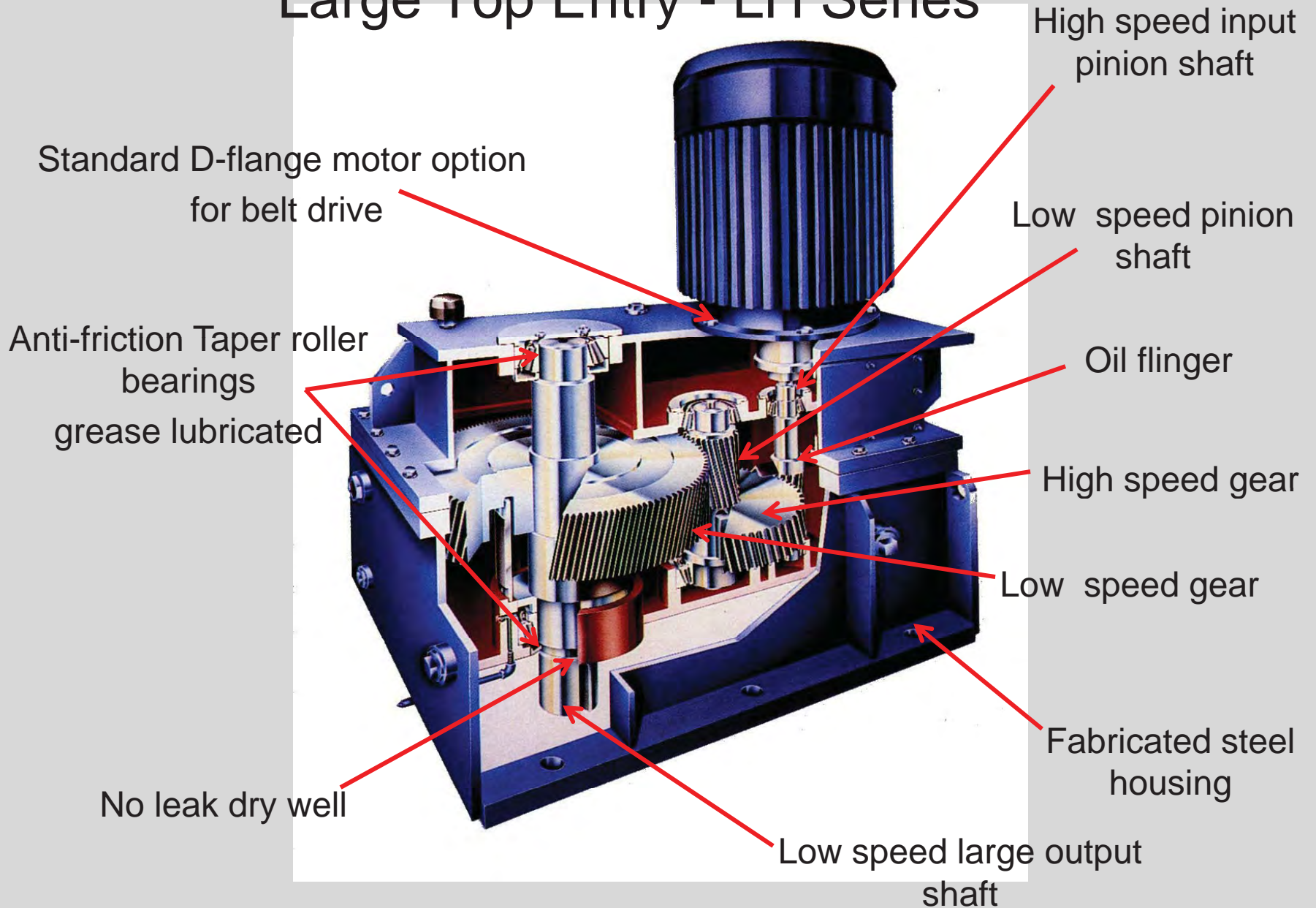

# Mixers Specialty & Custom Products

## Belt Driven Top Entry

- Primarily used for **Higher Speed Applications (>200 RPM)**. Often used on High Pressure Reactors.
- Horsepower range from **2 to 150**



# Mixer Specialty & Custom Products

## MagDrive Mixers

- Sealless design for 100% leakfree operation. Available in direct or geardrive configurations for top entry applications.
- Torque capability to 9000 in. lbs.
- Greased for life or dry running bearings.

