

**Horsepower: 5/ 7.5/ 10/ 15 & 20****SUBMERSIBLE SLURRY PUMP**

Designed to pump heavy abrasive materials up to 1" in diameter. 5 versions 2" pump are available with Off The Shelf Delivery.

**Features:**Semi-Open Impeller

- Adjustable Wear Plate increases wear life when pumpage contains heavy abrasive particles up to 1".

High Chrome

- Impeller, Casing and Wear Plate are made from High Chrome for extended wear life. Optional High Chrome Elbows available.

Slurry Mechanical Seal

- Dual Seals of Silicon Carbide vs. Silicon Carbide running out of slurry in its own chamber of barrier fluid.
- A labyrinth seal and relief port further protects the motor.

Premium Efficient Motor

- Inverter Duty, air filled, copper wound motor.
- Class H 200deg. C Motor insulation.
- Can handle hot abusive applications up to 180°F.+ water temperature.

Sump Agitation

- Spray holes are standard on every 2" EW pump.
- An agitator is optional for thick, heavy slurries.

Off The Shelf Delivery

- Pumps and Parts are available for immediate shipment.

**Applications:**

- Bottom Ash / Fly Ash
- Tailings Ponds
- Sand and Gravel
- Clean out Sumps
- Coke Pits
- Dredging
- Coal Pile Runoff
- Slag Pits
- Mill Scale
- Boiler Blow Down
- Lime Slurry
- Thickener Drain
- Mine Dewatering



**GPM** **inc. Sales and Service**  
 Engineered  
 4432 Venture Ave. | Duluth, MN 55811  
 Ph. (218) 722-9904 Fx. (218) 722-2826  
<http://www.eliminatorpumps.com/>

# SPECIFICATION (SBEW2)

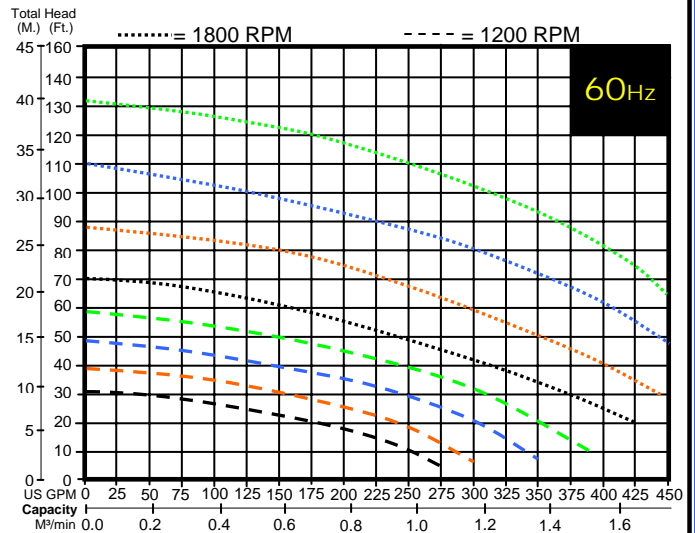
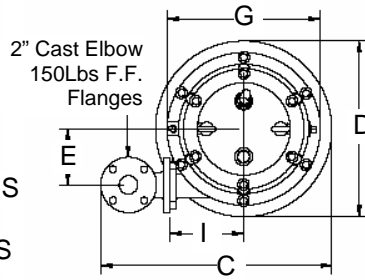
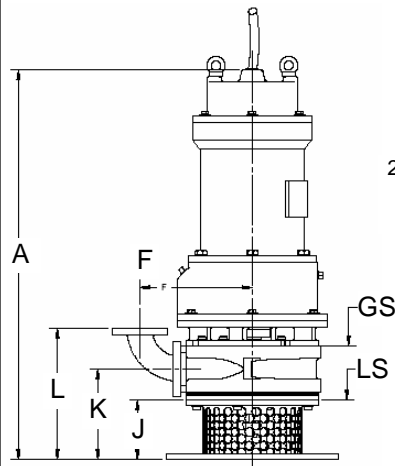

Dimensions Inches [Centimeters]															
Models	RPM	A	C	D	E	F	G	I	J	K	L	G.S.	L.S.	Weight	HP
SBEW2S5	1200	42.8 [1087]	24.9 [633]	19.0 [483]	6.0 [154]	12.4 [315]	16.5 [420]	7.9 [201]	6.5 [165]	9.6 [254]	13.4 [368]	12.3 [311]	6.5 [164]	675	5
SBEW2S7.5	1200	↓	↓	↓	↓	↓	↓	↓	↓	↓	↓	↓	↓	690	7.5
SBEW2S7.5	1800	↓	↓	↓	↓	↓	↓	↓	↓	↓	↓	↓	↓	705	7.5
SBEW2S10	1200	↓	↓	↓	↓	↓	↓	↓	↓	↓	↓	↓	↓	719	10
SBEW2S10	1800	↓	↓	↓	↓	↓	↓	↓	↓	↓	↓	↓	↓	711	10
SBEW2S15	1800	49.9	↓	↓	↓	↓	17.25	↓	↓	↓	↓	↓	↓	914	15
SBEW2S20	1800	↓	↓	↓	↓	↓	↓	↓	↓	↓	↓	↓	↓	925	20

## SPECIFICATIONS

## STANDARD

## OPTIONS

Horsepower .....	5 / 7.5 / 10 / 15 / 20	5Hp – 500HP
Discharge Size .....	2"	3" / 4" / 6" / 8"
Performance Range		
Capacity .....	25 - 450 US GPM	100 – 450 US GPM
Head .....	10' – 138' TH	10 – 350' TH
Solids Handling .....	1"	1" – 4.5"
Motor Nomenclature		
Type, Speed, HZ .....	TENV Air Filled / 1200 –1800 / 60Hz	Variable Speeds / 50Hz
Voltage, Phase, S.F., Cycle .....	480v. / 3Phase / 1.15 S.F. /	240 / 575 Available
Insulation .....	Class H / 200 Deg C Rated	
Cable Length .....	33'	Length as Required
Maximum Run Time in Air .....	1 Year	
Maximum Water Temperature .....	180° F.+	Water Jacket Available
Operation .....	Manual	Smart Control Available
Materials of Construction		
Casing / Impeller / Wear Plate .....	28% Chrome 650 Brinell Hardness	
Shaft .....	416 Stainless Steel	
Motor Housing .....	Cast Iron With 2Mil Epoxy Coating	
Fasteners .....	.316 Stainless Steel	
Impeller Type .....	Semi Open	Enclosed
Mechanical Seal		
Upper / Lower Seat .....	Silicon Carbide	
Upper / Lower Rotator .....	Silicon Carbide	
Elastomers .....	Viton	
Bearings .....	Permanently Lubricated Double Angular Contact	
Accessories .....		Discharge Hose / Float Controls / Elbows Steel or High Chrome / Rafts- Barges



**GPM inc. Sales and Service**  
 4432 Venture Ave. | Duluth, MN 55811  
 Ph. (218) 722-9904 Fx. (218) 722-2826  
<http://www.eliminatorpumps.com/>